

NEXT NORDIC GREEN TRANSPORT WAVE - LARGE VEHICLES

Analysis on large-scale transport of liquid
hydrogen on Nordic roads

Deliverable 2.6
September 2023

Table of contents

Next Wave – about the project	3
Summary	5
1. Background	6
2. Liquid hydrogen supply chain	8
2.1 Liquid hydrogen production	8
2.2 Liquid hydrogen storage	10
2.3 Liquid hydrogen delivery	12
2.3.1 Transporting liquid hydrogen	12
2.4 Liquid hydrogen use at HRS	15
2.4.1 Dispensing	16
2.5 On-board liquid hydrogen storage	17
2.6 Cryo-compression of liquid hydrogen	18
2.7 Liquid hydrogen delivery costs	18
2.7.1 Cost of transporting liquid hydrogen	18
2.7.2 HRS costs	19
2.7.3 Liquid hydrogen on-board tank costs	19
3. Hydrogen losses in liquid hydrogen supply chain	20
4. Liquid hydrogen in the Nordic countries	21
4.1 Finland	22
4.1.1 Liquid hydrogen projects	22
4.1.2 Liquid hydrogen delivery	22
4.2 Sweden	24
4.2.1 Liquid hydrogen projects	24
4.2.2 Liquid hydrogen delivery	24
4.3 Norway	25
4.3.1 Liquid hydrogen projects	25
4.3.2 Liquid hydrogen delivery	26
4.4 Iceland	27
4.4.1 Liquid hydrogen projects	27
4.4.2 Liquid hydrogen delivery	27
4.5 Denmark	28
4.5.1 Liquid hydrogen projects	28
4.5.2 Liquid hydrogen delivery	28
5. Case study – Delivery of hydrogen in Finland	30
5.1 Delivery cost analysis	30
5.2 Cost model structure	32
5.3 Hydrogen production	33
5.4 Processing/Compression	34
5.5 Trucking	37
5.6 Liquefaction	38
5.7 Storage	39
5.8 Dispensing	41
5.9 Results	41
6. References	46
7. Appendix	48
7.1 Methodology for calculating the number of trucks and trailers required	48
7.2 Methodology for calculating trucking costs	49

Next wave - about the project

Electrification of the transport sector already began and the Nordic countries, specifically Norway and Iceland, have taken major steps resulting in battery electric vehicles (BEVs) already accounting for a substantial percentage of the total sales. The world is looking towards the Nordics as they are providing global examples for success. However, little is happening regarding larger vehicles as battery solution still are not able to provide heavy-duty users (e.g., buses, trucks, and lorries) the mobility they need.

Fuel cell electric vehicles using hydrogen as a fuel can solve this. The project focuses on providing infrastructure for a large-scale deployment of trucks, buses, and lorries. The goal is to further stimulate the global technological lead, which the Nordic countries have by stimulating the very first hydrogen infrastructure roll-out for larger vehicles while at the same time map how the infrastructure build-up needs to be done, so that the transition to hydrogen vehicles can happen smoothly. Such roll-out will also benefit the use of hydrogen for trains and the maritime sector. Furthermore, in addition of sourcing the hydrogen as a by-product from the industry, in the Nordic region we have the unique opportunity to produce the hydrogen in a green manner exploiting renewable electricity production.

Already, Nordic industries have taken international lead in the field of hydrogen and fuel cells and a unique cooperation exists between "hydrogen companies" via the Nordic Hydrogen Partnership (former Scandinavian Hydrogen Highway Partnership, SHHP) cooperation. Jointly they have marketed the Nordic platform for hydrogen and, at the same time, paved the way for vehicle manufacturers to deploy such vehicles in the Nordic countries. When it comes to hydrogen, the Nordics have globally leading companies both within the infrastructure and the fuel cell business. The project therefore sets forward four key activities in a unique project where technical innovation and deployment strategies are intertwined.

The project will deliver an analysis on large-scale transport of hydrogen with mobile pipeline, a description of the innovation and business potential for a roll-out of FC-buses in the Nordic region, as well as a coordinated action plan for stimulating the FC (Fuel Cell) truck demand and a prospect for utilising hydrogen in heavy-duty equipment. Finally, the project will contribute to national and Nordic hydrogen strategy processes even providing input to a possible Nordic Hydrogen Strategy.

Partners in Next Wave:



Authors:

Norwegian Hydrogen Forum: Jan Carsten Gjerløw, Lin April Løstegård

Kunnskapsbyen Lillestrøm: Jon Eriksen

VTT: Aleksandra Saarikoski, Lauri Vänttinen, Jari Ihonen

Hydrogen Sweden: Björn Aronsson

Icelandic New Energy: Jón Björn Skúlason

Hydrogen Denmark: Tejs Laustsen Jensen

Disclaimer:

This publication is part of the Nordic Smart Mobility and Connectivity initiative **Next Wave** (Next Nordic Green Transport Wave - Large Vehicles) co-financed by **Nordic Innovation**. The project partners are responsible for its content.

Summary

New solutions for decarbonizing the transport sector are needed. One of these solutions is liquid hydrogen, which is a suitable fuel for many applications like trucks and maritime vessels. Research and development of liquid hydrogen systems for airplanes can decrease the weight of the storage systems which benefits all applications where weight or payload is important. In the past, liquid hydrogen has been used for rocket fuel.

The benefit compared to gaseous hydrogen is the gravimetric density. Net payload in hydrogen transport can be up to 6-7 tonnes per truck in Finland, while for gaseous hydrogen it is about 2 tonnes per truck.

Liquid hydrogen is created from gaseous hydrogen by liquefaction. Liquefaction plants are typically large in scale to increase cost efficiency because of the expensive investments. The process itself is energy demanding which increases the energy costs. Liquid hydrogen is stored in well insulated storage tanks to minimize heat transfer between the tank and its surroundings. In some applications additional cooling is not needed, but generally, evaporation (boil-off) of hydrogen must be considered in the process. Liquid hydrogen can be stored on-site, transported using trucks or vessels, and bunkered in the ports.

The Nordic countries do not currently have production or a high market demand for liquid hydrogen, but there is a huge potential. For example, in Norway there is a number of ongoing activities towards infrastructure, production, and use of liquid hydrogen. A good example being the liquid hydrogen powered ferry MF Hydra that recently started operation, although in the absence of liquid hydrogen production in Norway - the hydrogen for MF Hydra currently being sourced from Germany. As a product, liquid hydrogen has a higher value than gaseous hydrogen and it could be exported to other countries. Nordic countries could be in the forefront of liquid hydrogen production and capitalize the available renewable energy and the increasing hydrogen market demand in Europe.



Photo: Jörn Sieveneck, Unsplash

1. Background

Liquid hydrogen is not yet commonly available. It has, however, been used as a rocket fuel since the 1960's and was introduced in maritime fuel cell applications in March this year. Use of hydrogen in heavy-duty applications in road traffic and working machines (non-road mobile machinery, NRMM) will create a market for more hydrogen, thus boosting production and lower the price of liquid hydrogen.

The global liquid hydrogen production capacity is mainly focused on Northern America with some production in Europe and Asia. Liquid hydrogen is produced mostly in the USA where the production capacity was 241 tonnes per day in 2019 with extra capacity of over 90 tonnes per day planned for 2021. As a comparison, in Europe, the production capacity was 20 tonnes per day in 2019, but more capacity is planned. In Asia, the largest liquid hydrogen producer is Japan with a capacity of approximately 30 tonnes per day (Cardella, 2019).

Large amount of hydrogen is available in Finland, Sweden, and Norway as a by-product from industrial processes (Ihonen et al., 2020). Currently the utilisation of by-product hydrogen is very high in Sweden and Norway, but in Finland by-product hydrogen is not utilized to the full potential, which makes it an excellent fuel for the transport industry. The by-product hydrogen needs to be purified in order to be used as a fuel for the transport vehicles.

Hydrogen can be produced on-site or transported to the refuelling station. For on-site production, usually electrolysis is used, where hydrogen is separated from water. In addition, the hydrogen can be produced centralized and in a bigger scale using e.g., renewable energy for electrolysis. When produced centrally, the hydrogen can be transferred in pipelines or by trucks as a gas, or it can be liquefied, stored, and transported to the refuelling station in tanks pulled by trucks. Storing energy as hydrogen also creates a buffer for fluctuating sources of renewable energy and the storage can be used to cover peaks in demand.

Cryogenic tanks must be used for liquid hydrogen, which could decrease the cost of transport because of higher payloads. The feasibility of the best solution is dependent on the location, supply, and demand where the different components must match to create a competitive solution.

Liquid hydrogen (LH₂) has picked up much attention lately as a fuel e.g., in the maritime sector. A good example is the MF Hydra, the first liquid hydrogen powered ferry, that recently started operating in Norway¹. In addition, LH₂-technology is planned to be used in some trucks, while 700 bar is used in passenger vehicles.

An obligation regarding LH₂ distribution was initially a part of the proposal of EC (European Commission) for revision of the regulation on the deployment of alternative fuels infrastructure (AFIR - COM(2021) 559 final) which was later removed when the provisional agreement² (AFIR - 2021/0223 (COD)) was reached. Regardless of this, LH₂ might become important with a well-defined hydrogen market where large amounts of hydrogen are transported over longer distances, especially if heavy-duty vehicles are powered by LH₂. It is an open question if it is better to produce LH₂ in each country or whether it is better to export and import it between countries which, again, could ease the load of the power grid.

Many manufacturers of hydrogen fuel cell vehicles have been initially investing in powertrains using gaseous hydrogen. This has been the best solution, but liquid hydrogen could be a suitable alternative in some cases. Liquid hydrogen needs a cryogenic tank which needs to be well insulated to minimize the evaporation of hydrogen, also referred to as boil-off. The advantages of liquid hydrogen are purity and high gravimetric and volumetric density.

Liquefaction of hydrogen makes the transport over long distances more efficient due to the higher payloads transported. The road regulations and laws in Nordic countries have maximum dimensions and weights for the road transports and with liquefied hydrogen the payload is higher compared to gas tanks that are large in volume, but the density of the hydrogen is smaller. Even with liquefied hydrogen, the limit for road transport is still the volume, not the weight. This was further discussed in the Next Wave Deliverable 2.2 - Large-scale hydrogen use in Nordic industry 2020-2030³.

¹ <https://www.vegvesen.no/om-oss/presse/aktuelt/2023/03/mf-hydra-sails-on-zero-emission-liquid-hydrogen/>

² [https://oeil.secure.europarl.europa.eu/oeil/popups/ficheprocedure.do?reference=2021/0223\(COD\)&l=en](https://oeil.secure.europarl.europa.eu/oeil/popups/ficheprocedure.do?reference=2021/0223(COD)&l=en)

³ https://www.nordichydrogenpartnership.com/wp-content/uploads/2021/06/Next-Wave-D2_2-Large-scale-hydrogen-use.pdf

2. Liquid hydrogen supply chain

2.1 Liquid hydrogen production

Liquid hydrogen is created by liquefying gaseous hydrogen. To liquefy hydrogen, the hydrogen is cooled down to its critical temperature of -240°C and then stored at -253°C . Liquefaction of hydrogen through cryogenic cooling reduces the volume of hydrogen by 1/848 compared to gaseous hydrogen at standard conditions (1 atm, 15°C) (Aziz, 2021).

In 2019, the hydrogen liquefaction capability in Europe was approximately 20 tonnes a day while an additional 5.3 tonnes were planned for 2021 (Cardella, 2019). This needs to be increased heavily when the on-road and maritime transport start using hydrogen as the fuel.

The liquefaction of hydrogen needs the right temperature and pressure. To achieve this, the process flow by Linde is shown in *Figure 1* (Cardella, 2019). The hydrogen gas is fed into the cold box while compressed (if needed). It flows through a precooling system before entering the cryogenic refrigeration and liquefaction. After precooling, cryogenic purification can be performed. The system requires electricity, refrigerants, cooling water, instrument air, and nitrogen.

Simplified process flow diagram for hydrogen liquefaction

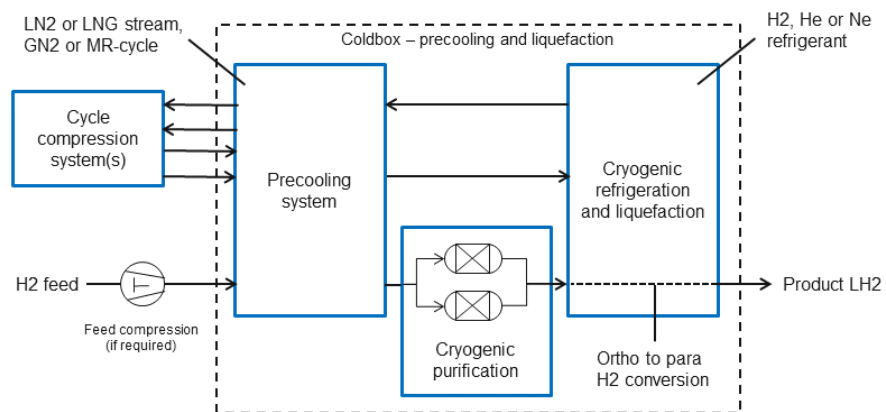

Figure 1. Simplified liquefaction process flow adapted from (Cardella, 2019).

Large-scale production is needed for the liquefaction to be cost and energy efficient. Until large liquefaction plants are available, the cost of liquid hydrogen will most probably be significantly more expensive than gaseous hydrogen. The cost for the infrastructure is quite high and market demand is needed for the investment. Although, a possibility exists that the capital costs of liquefaction would decrease in the future. Producing, transporting, and storing liquid hydrogen is more feasible if the hydrogen is used as a liquid also in the end application meaning that it is stored as liquid also in e.g., trucks.

Air Liquide has opened its world's largest liquid hydrogen production plant in North Las Vegas, Nevada, USA. The production capacity of the plant is 30 tonnes of liquid hydrogen per day, which can provide hydrogen for over 40,000 fuel cell vehicles. The investment for the plant was \$250 million (Air Liquide, 2022).

The cost level for this size of plant would mean that only CAPEX would add ~2-4 \$/kg for the hydrogen price. It is clear that cost level of liquid hydrogen production must decrease either due to series production of smaller plants or due to larger plant size. Although, savings to the hydrogen cost are achieved in the LH₂ supply chain when hydrogen is transported, stored, and compressed at the hydrogen station.

The investment cost of hydrogen refuelling stations is significant. To make the investment more feasible, the refuelling stations shall be able to refuel multiple types of vehicles, meaning trucks, buses and other smaller vehicles using liquid or gaseous hydrogen as the fuel. The challenge to produce hydrogen and refuelling infrastructure needs clear strategies and investments from the Nordic countries and the European Union. Larger volumes will decrease the price of the infrastructure and the hydrogen, which may lead to prices lower than currently seen for fossil fuel.

The best method of transporting hydrogen to the refuelling station is dependent on the demand and size of the refuelling station. If there are only few small refuelling stations, the best way to supply the hydrogen is by transporting it on road as a gas. For a larger refuelling station, local electrolysis would be a good option. Transport on road would be an option to compensate for the peak demand where the local electrolysis production is not enough. For a larger network of refuelling stations, hydrogen pipeline would be a good solution. Liquid hydrogen is worth considering when the scale of the production decreases the price. The optimal solution is found by analysing multiple parameters, such as electrolyser cost, hydrogen compression cost, transportation cost, as well as hydrogen storage cost and regulations (Ihonen, Viik, et al., 2021).

The energy consumption for hydrogen liquefaction is shown in *Figure 2*. According to (Cardella, 2019) the energy consumption for a small-scale liquefier (including precooling) is 12-14 kWh/kgH₂, for a medium-scale liquefier 7.5-12 kWh/kgH₂, and for a future large-scale liquefier 6-7.5 kWh/kgH₂. Small-scale here is <3 tonnes per day (tpd) capacity, medium scale is 2-50 tpd capacity, and large-scale is >50 tpd capacity. Liquefaction cost reduction by nearly 70% is possible in liquefaction plants at a 100 tpd capacity.

Specific energy consumption of liquefaction

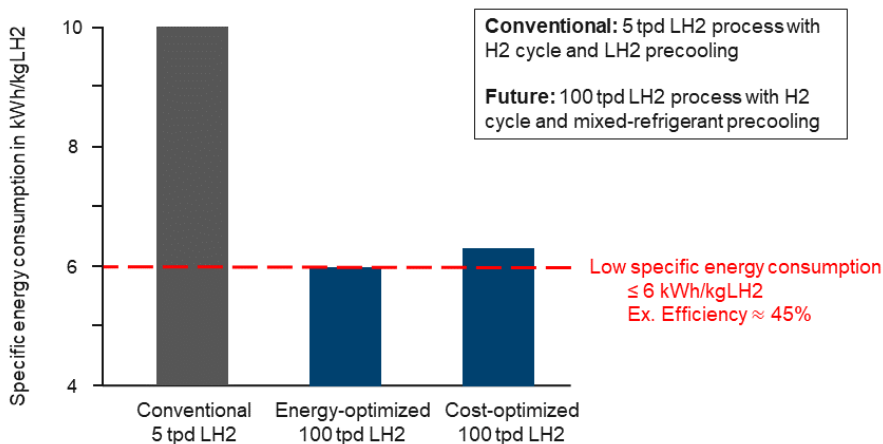

Figure 2. Energy consumption for hydrogen liquefaction adapted from (Cardella, 2019).

The electrical energy consumption for liquefaction increases the carbon footprint for LH₂. The production of hydrogen can take place when there is additional low carbon electricity available. However, high capital cost for hydrogen liquefaction plants means that it must be operated almost all the time. In most parts of Europe, electricity for liquefaction would then have high CO₂ emissions, as liquefaction is not a flexible process. This clearly favours LH₂ production in Nordic countries where CO₂ emissions from electricity production are low almost all of the time.

Several initiatives, such as the Institute for Energy Technology (IFE) coordinated 5-year Clean Hydrogen Partnership (EU) project *Development and validation of a new magnetocaloric high-performance hydrogen liquefier prototype* or the Helmholtz-Zentrum Dresden-Rossendorf (HZDR), TU Darmstadt, and the start-up MAGNOTHERM initiative, are working on an alternative method to liquefy hydrogen by means of magnetic cooling to significantly increase the efficiency of hydrogen liquefaction. Magnetic cooling of hydrogen is based on magnetocaloric materials that change their temperature when exposed to a magnetic field. The method would not require a compressor. The method is supposed to result in an energy consumption reduction of 50% compared to the conventional method⁴.

2.2 Liquid hydrogen storage

A few different storing options exist for liquid hydrogen. The first alternative is storing liquid hydrogen at normal pressure which is the most common option. Other options include cryo-compression at elevated pressure and slush hydrogen. Liquid hydrogen storage generally aims at minimizing the boil-off to avoid losses.

Large-scale liquid hydrogen storage has not developed much since the 1960's, mostly being stored by means of spherical or cylindrical well-insulated large tanks. The largest liquid hydrogen storage facility is located at Florida, United States at NASA's Kennedy Space Center. The storage itself is a double-walled vacuum insulated sphere with a storage capacity of 3,200 m³ (International Energy Agency (IEA), 2022).

To store liquid hydrogen, a well-insulated tank is required. A small amount of hydrogen will evaporate, since there is always some heat transfer from the ambient into the tank even with good insulation. The process needs to take this into account: cool the tank and vent or use the evaporated hydrogen in a fuel cell to create power. The evaporating hydrogen, also called boil-off, can be used for stand-by cooling. For example, Linde's Hydrogen FuelTech liquid hydrogen fuelling stations with a cryopump uses boil-off hydrogen for stand-by cooling of the gaseous compressed hydrogen that is being put into the tank of the vehicle and requires no additional cooling system for the supply. The amount of boil-off is 4 kg/day when the bulk storage capacity is 400 kg of liquid hydrogen (Cardella, 2019). Daimler also states that no additional cooling is needed in their prototype truck using liquid hydrogen in a well-insulated tank (Daimler, 2022). Although, liquid hydrogen cooling would require such low temperatures that cooling in a small scale is not practically possible.

⁴ <https://www.hzdr.de/db/Cms?pNid=99&pOid=68660>

Cryo-compression refers to cryogenic liquid storage under pressure which leads to reduced amounts of evaporation and boil-off, higher density, and an increase in pressure build-up time. Although, pressurization helps with the boil-off temporarily, it does not fix the problem in the long-run. When the pressure limit of the storage tank or vessel is reached, a ventilation valve will have to release the pressure anyway (Aziz, 2021).

The materials, tank design, and expensive infrastructure pose a challenge for liquid hydrogen technology. The materials used for the components in direct contact with liquid hydrogen like the pipes, tank, vessel, vents, valves etc. must be designed to the extremely cold temperatures of the liquid hydrogen, and formation of ice on the outer surface of the components should be minimized to avoid any material damage (Aziz, 2021).

The materials must be selected in a way that the effects of hydrogen embrittlement, permeability are minimized. The material properties shall also be suitable to accommodate changing temperatures that cause thermal expansion and contraction. Generally, the storage vessels have double walls with a vacuum in between to create a layer of insulation. In this vacuum layer, other materials like foams or metal can be added as layers to increase the performance. The vessels are generally manufactured using stainless steel and aluminium or lightweight reinforced fibre materials with a metallic inner layer (Aziz, 2021).

Unlike the storage vessels designed for gaseous hydrogen, the liquid hydrogen storage vessels are not designed to withstand high pressures, except with cryo-compression. A pressure relief valve is needed to safeguard the pressure inside the storage vessel. The venting/purging system is designed to not let any air in avoiding freezing of the lines. With a cryo-compressed tank both gaseous and liquid hydrogen can be stored as the tank operates at a higher pressure (Aziz, 2021).

Liquid hydrogen has unique properties in comparison to gaseous hydrogen which should be considered in storage system safety design. Liquid hydrogen differs from gaseous hydrogen as it is stored in extremely low temperatures. The equipment should be handled properly, and no contact should be made with the liquid hydrogen or its vapour to avoid the risk of severe burns. In case of a leakage from a liquid hydrogen storage, the hydrogen that vaporizes to gas has different features than gaseous hydrogen for a brief period of time due to its temperature immediately after vaporization. The density of the hydrogen gas is higher, and it acts as a dense gas and can accumulate at a low level. Cold hydrogen can potentially lead to a rapid phase transition explosion if it comes in contact with a hot liquid. These factors are important to keep in mind when designing a liquid hydrogen storage. Therefore, a liquid hydrogen storage tank is equipped with safety measures, including overfilling protection, pressure-relief valves, rupture discs, and pressure-safety valves (Aziz, 2021).

E4Tech estimated in 2015 that storing 16,000 m³ of liquid hydrogen would cost around 30 million € with the boil-off of 0.25% per day and a lifetime of 20 years for the years 2014-2050. This means that the storage would cost around 1,875 €/m³. The values are based on a 2010 estimate (Hart et al., 2015). According to an estimate by the U.S. Department of Energy (2015) the cost of storing liquid hydrogen in a 3,500 m³ tank is around 1,730 €/m³ in 2015-2020

and the ultimate target cost with a well-established hydrogen market is around 865 €/m³. Although, the cost estimates by the U.S. Department of Energy are uninstalled costs and the installed costs are of course higher. As an example, with an installation factor of 1.3, the costs would total ~2,250 €/m³ for liquid hydrogen storage in 2015-2020. This gives a general idea of the cost of hydrogen storage. In the case study in *Section 5*, a fixed cost estimate per kg of hydrogen is considered for hydrogen storage as in the Next Wave Deliverable 2.5 - Detailed analysis for large-scale hydrogen transport in Finland⁵.

2.3 Liquid hydrogen delivery

Liquid hydrogen transportation from the production site to applications is often referred as hydrogen delivery (Cebolla et al., 2022; U.S. Department of Energy, 2015).

2.3.1 Transporting liquid hydrogen

As mentioned above, transporting hydrogen as a liquid is an attractive option because it enables a more efficient delivery for longer distances than for gaseous hydrogen because of higher payloads. Until now, liquid hydrogen delivery from the production point to the user has focused on road transport, which is the most common mean of transporting liquid hydrogen (Cebolla et al., 2022). Alternatives to liquid hydrogen delivery by road are delivery by marine vessels or railways. Although, the focus in this report is mainly on road transport.

Different amounts of liquid hydrogen can be transported with different methods. The largest quantities of liquid hydrogen are typically transported at sea by means of marine vessels, such as the LH₂ carrier Suiso Frontier shipping LH₂ from Hastings in Australia to Kobe in Japan, that has a capacity of approximately 75 tonnes of LH₂ (International Energy Agency (IEA), 2022). Through rails, a tank of approximately 8,000 kg could be used for liquid hydrogen transportation. Through roads, 2,100-4,200 kg could be transported (Aziz, 2021). Although, Finland and Sweden allow larger payloads to be transported on their roads and therefore more than 4 tonnes of hydrogen could be transported with one truck.

Liquid hydrogen delivery by road transport includes several options, including a semi-trailer solution, a portable tank, or a standardized ISO-tank solution. Possible portable tank solutions for liquid hydrogen transport are either based on the 30 ft or 40 ft ISO sized frames. Although, 45 ft container configurations could be used, especially in the Nordics with some exceptions. With a standard ISO 40 ft container, around 3 tonnes of liquid hydrogen could be transported. A 45 ft container would fit around 3.5-4 tonnes of liquid hydrogen. The amount of liquid hydrogen transported depends on the type of container and insulation (Decker, 2019). An example of a liquid trailer is shown in *Figure 3*.

⁵ https://www.nordichydrogenpartnership.com/wp-content/uploads/2022/06/Next-Wave-D2_5-Detailed-analysis-for-large-scale-H-transport-in-Finland.pdf

Several companies offer cryogenic liquid semi-trailers, also for liquid hydrogen. The 45 ft semi-trailer solution provided by Linde has a liquid hydrogen capacity of around 4 tonnes with a 5% ullage⁶ (Decker, 2019). Ullage usually comprises 5-10% of the volume (Cebolla et al., 2022). Other providers also offer semi-trailer or portable tank solutions for transporting liquid hydrogen, such as Gardner Cryogenics⁷ and Chart⁸. The two liquid trailer types Chart offers could carry around 4-4.3 tonnes of liquid hydrogen, depending on the configuration. A summary of LH₂ trailers is presented in *Table 1*.

Table 1. Liquid hydrogen trailers

Provider	Type	Payload (kg)	Size
Chart	ST-17600H 155 ⁹	4,340	Length = 50 ft Width = 2.6 m Height = max 13 ft
Chart	ST-8500H 110 ¹⁰	2,096	Length = 8.51 m Width = 2.6 m Height = max 4 m
Gardner Cryogenics	Portable 40 ft LH ₂ tank ⁷	2,600	40 ft ISO frame
Gardner Cryogenics	Semi-trailer ⁷	Max. 4,400	-
Linde	LH ₂ trailer (Decker, 2019)	4,000	Length = 45 ft
Linde	HYLICS (Decker, 2019)	3,000	40 ft ISO frame

The boil-off in a liquid tanker is estimated to be around 0.3-0.6% per day, while additional losses could be expected due to handling, e.g., the transfer of the liquid hydrogen from one container to another (Aziz, 2021).

Compared to gaseous hydrogen, liquid hydrogen could enable the transportation of significantly larger amounts of hydrogen. Gaseous hydrogen is usually transported using tube trailers or compressed gas transport containers. In one standard 40 ft hydrogen transport container at 200 bar, approximately 460 kg can be transported. By means of a so-called high cube 40 ft, 200 bar container, this can be increased to 559 kg of hydrogen. The hydrogen content that can be transported in a single container increases with the pressure level. As an example, by increasing the pressure of a standard 40 ft container from 200 bar to 500 bar, the amount of hydrogen that can be transported increases from 460 kg to 1,100 kg. Now, the amount of hydrogen that can be transported

⁶ The amount by which a container falls short of being full.

⁷ <https://www.energy.gov/sites/default/files/2022-03/Liquid%20H2%20Workshop-Gardner%20Cryogenics.pdf>

⁸ <https://www.chartindustries.com/Products/Cryogenic-Transport-Trailers>

⁹ https://files.chartindustries.com/21746492_LH2Trailer.pdf

¹⁰ https://files.chartindustries.com/21898781_ST8500_LH2_Trailer.pdf

with a liquid hydrogen trailer is approximately three to four times more than what can be transported with a gaseous hydrogen transport container even when the pressure is increased to 500 bar. Further comparison of the payloads and dimensions of hydrogen transport containers is presented in the Next Wave Deliverable 2.2¹¹. A comparison of gaseous and liquid hydrogen transport container payloads is shown in *Table 2*.

Table 2. Comparison of gaseous and liquid hydrogen transport container payloads adapted from Next Wave Deliverable 2.2

Transport mode	Payload of one standard 40 ft container
Gaseous H ₂ at 200 bar	457 kg (559 kg with high cube)
Gaseous H ₂ at 300 bar	658-835 kg (804 kg with high cube)
Gaseous H ₂ at 500 bar	~1,100 kg (~1,200 kg with high cube)
LH ₂	~3 tonnes

Although, the concept of liquid hydrogen shipping is being tested, liquid hydrogen delivery by means of marine vessels is not commercially available today. The recently kicked-off Hydrogen Energy Supply Chain (HESC) pilot project is paving the way where LH₂ is shipped from Hastings in Australia to Kobe in Japan with the world's first LH₂ carrier ship, Suiso Frontier. The ship is designed and built by Kawasaki and has a capacity of 1,250 m³, which corresponds to approximately 75 tonnes of liquid hydrogen (International Energy Agency (IEA), 2022). This corresponds to approximately 25 containers of LH₂.

Another alternative for liquid hydrogen transportation is the railway. Currently, however, liquid hydrogen is not transported by trains, but this is an attractive option for the future due to the possibility to efficiently transport larger amounts of hydrogen¹². As an example, Chart offers cryogenic railcars for the transportation of cryogenic liquids, such as liquid argon, oxygen, and nitrogen¹³. The sizes might vary: the tank car solution offered for LNG has the capacity of ~106 m³ and the ISO LNG fuel tender that supplies fuel to the powertrain has a capacity of 41.6 m³. These systems are designed for the railways in the U.S. There is a possibility that similar technology could be used in the future for transporting liquid hydrogen through rails. In addition, the German railway company Deutsche Bahn is looking into opportunities of transporting liquid hydrogen by rail tank cars and hydrogen powered trains¹⁴.

¹¹ https://www.nordichydrogenpartnership.com/wp-content/uploads/2021/06/Next-Wave-D2_2-Large-scale-hydrogen-use.pdf

¹² <https://www.pv-magazine.com/2020/08/10/hydrogen-can-be-transported-by-rail-german-railway-company-says/>

¹³ <https://www.energy.gov/sites/prod/files/2019/04/f62/fcto-h2-at-rail-workshop-2019-nason-larson.pdf>

¹⁴ <https://www.industryandenergy.eu/hydrogen/large-quantities-of-hydrogen/>



Figure 3. Liquid trailers.

2.4 Liquid hydrogen use at HRS

At the Hydrogen Refuelling Station (HRS), hydrogen could be stored either as a compressed gas, liquid, or cryo-compressed liquid. Although, case specific solutions for hydrogen refuelling stations exist, liquid hydrogen storage solutions at an HRS could be similar to large-scale liquid hydrogen storage for transport - including trailer swap where the trailer acts as a mobile storage tank for the HRS. A swappable container with LH₂ could be transported to the HRS via rails, roads, or sea, and swapped to an empty one.

Storing hydrogen as a liquid in a large tank at the HRS requires less storage space when compared to gaseous hydrogen. In order to minimize the losses due to boil-off, the boil-off gasses should be utilised as gaseous hydrogen at the HRS or as a fuel for the unit cooling the storage.

For ships and other maritime vessels, liquid hydrogen is typically bunkered in the ports or by means of bunker vessels. The bunker vessel can store liquid hydrogen and discharge it to the tanks of another vessel as needed. Currently, the bunker solutions are provided project-by-project, as there is no established supply chains and bunkering hubs. This drives up the cost for using liquid hydrogen, but the cost reductions are expected to be rapid as the market increases.

2.4.1 Dispensing

Several different HRS layouts are under development. Liquid hydrogen can be dispensed from the HRS as cryo-compressed LH₂, subcooled LH₂, or as compressed gas hydrogen depending on the powertrain used. As of today, dispensing of gaseous hydrogen dominates and liquid hydrogen dispensing being not so common, especially not for HRS layouts intended for road transport. Despite gaseous dispensing being the most common technology today, it's the technology on-board the vehicle that really matters. As an example, Daimler Truck¹⁵ has two 40 kg liquid hydrogen tanks on-board their trucks put into tests last year and thus would require liquid dispensing (Daimler, 2022). In case the hydrogen at the HRS is already stored as a liquid, only a liquid pump would be required.

For liquid hydrogen, popular HRS layouts include either an evaporator with a compressor or a cryogenic pump to dispense gaseous hydrogen. In the first alternative, liquid hydrogen is evaporated with ambient heat and then compressed up to 950 bar for intermediate storage. Then, the hydrogen is pre-cooled to <-40°C before being dispensed to the vehicle tank. In the latter HRS layout, liquid hydrogen is pressurized into a supercritical state up to 950 bar with a cryogenic pump. The cryogenic hydrogen can then be gasified with an evaporator and dispensed to the vehicle tank. This is a more energy efficient alternative since the cryogenic pump uses approximately 10-20% of the energy required for gaseous compression (Genovese & Fragiaco, 2023).

Linde offers HRS solutions for liquid hydrogen supply supporting both 350 bar and 700 bar vehicle tank systems, and with alternative maximum capacities of hydrogen dispensed per day. The layouts include cryogenic pumps that initially compresses liquid hydrogen to around 6 bar and further compresses gaseous hydrogen to around 900 bar. Then the hydrogen can be dispensed as gaseous hydrogen at the chosen pressure level¹⁶.

While there already has been established European and international standards such as for dispensing of gaseous hydrogen, road vehicle fuelling connections, and hydrogen fuel quality, there is currently no established standards for dispensing of liquid hydrogen. Liquid hydrogen standards are, however, being developed, such as ISO/AWI 13984 which will specify the characteristics of liquid hydrogen refuelling and dispensing systems on land and replace the previous version of ISO 13984:1999¹⁷. A standardization request (M/581) has been made by the European Commission to develop European standards for heavy-duty vehicles regarding a unified solution for hydrogen refuelling points dispensing compressed (gaseous) hydrogen but also liquefied hydrogen. The technical committee 268 is also developing standards for maritime and inland vessels related to request M/580 to create a unified solution for compressed gaseous and liquefied hydrogen refuelling and bunkering (ECH2A, 2023).

¹⁵ An offshoot of Mercedes-Benz.

¹⁶ https://www.linde-gas.com/en/images/RLD_01_K19004_15_Hydrogen_Fuel_Tech_Broschuere_RZ_VIEW_tcm17-610582.pdf

¹⁷ <https://www.iso.org/standard/86295.html>

2.5 On-board liquid hydrogen storage

As discussed in the previous section, liquid hydrogen could be dispensed and stored on-board the vehicle as gaseous hydrogen or liquid hydrogen. While gaseous hydrogen in the on-board storage tanks could have a pressure of 350 bar or 700 bar, liquid hydrogen on-board the vehicle could either be stored in lower pressures as liquid hydrogen or as cryo-compressed hydrogen at around 260 bar (Aziz, 2021).

On-board storage of liquid can be done with or without a liquid hydrogen pump on-board the hydrogen vehicle. Avoiding the pump simplifies the system on the expenses of a lower capacity and reduced dormancy. These are results of the fact that the storage pressure must always remain higher than the fuel cell inlet pressure. Thus, the storage temperature must be higher, corresponding to a lower liquid hydrogen density, which again leads to a reduced LH₂ storage capacity. Also, the pressure difference of the storage and allowed pressure is reduced, leading to a reduced dormancy period between cooling cycles. On the other hand, the space saved by avoiding a pump in the system might be used for a larger storage volume that could compensate for some of this hydrogen capacity reduction (Ahluwalia et al., 2023).

Passenger car manufacturers often focus on dispensing and storing hydrogen as compressed gas. Although, heavy-duty vehicles often travel for longer distances and therefore on-board liquid hydrogen storage is an attractive option. This is the case with the new GenH2 fuel-cell truck with two 40 kg liquid hydrogen tanks from Daimler mentioned in the previous section. The objective of the truck is to have a range of up to 1,000 km or even more (Daimler, 2022). Furthermore, on-board liquid hydrogen storage is an attractive alternative also in ferries and trains.

Liquid hydrogen would also be faster to refuel than compressed hydrogen gas. The Korean Railroad Research Institute and Hyundai Rotem are developing the world's first LH₂-locomotive. The aim is to achieve a distance of 1,000 km and a maximum speed of 150 km/h with a single load (Ustolin et al., 2022). In addition, in the end of March 2023, the world's first ferry that runs on liquid hydrogen, MF Hydra, started its operation. It is operated in Norway by Norled¹. Due to the current lack of LH₂ production in Norway/Scandinavia, at this point the LH₂ for the ferry is imported from Germany.

As mentioned above, liquid hydrogen standards are currently being developed. This applies also to the on-board tanks since the international standard ISO 13985:2006 is being renewed and replaced by ISO/AWI 13985 which will specify the construction requirements for on-board liquid hydrogen tanks in land vehicles¹⁸.

¹⁸ <https://www.iso.org/standard/86294.html>

2.6 Cryo-compression of liquid hydrogen

Cryo-compression of liquid hydrogen combines cryogenic liquid and compressed storage. It results in a higher storage density than liquid hydrogen and includes no phase change. The storage of cryo-compressed hydrogen increases the dormancy and reduced boil-off in the short-run since higher pressures are allowed. Challenges with cryo-compression include tank design and materials, and the cost of refuelling infrastructure (Aziz, 2021).

Cryo-compressing liquid hydrogen is seen as an attractive option because it results in a higher storage density compared to sub-cooled liquid hydrogen and stored gaseous hydrogen in 350-700 bar pressure. The main challenges with cryo-compression include tank design, materials, and costs (Aziz, 2021).

2.7 Liquid hydrogen delivery costs

Here, an overview of the costs of hydrogen refuelling stations and transporting liquid hydrogen are summarised. For a more detailed break-down of the costs, please consult the case study in *Section 5* that investigates the costs of delivering liquid and gaseous hydrogen in Finland.

2.7.1 Cost of transporting liquid hydrogen

Liquid hydrogen is currently not widely transported. As of today, its use is focused almost solely on Northern America due to space-related applications. However, transportation solutions are available for road transport, including liquid hydrogen trailers which are considered as mature technology. Also, as discussed above, marine and railway applications are being developed/introduced these days, but so far marine and railway transport solutions are currently almost non-existent.

When transporting hydrogen, the core difference between gaseous hydrogen and liquid hydrogen is the type of the trailer. For gaseous hydrogen transport, a hydrogen transport container or tube trailer is used, while for LH₂ transportation is carried out by means of a liquid tank trailer. Liquid tank trailers are often expensive compared to tube trailers but have a higher payload. The cost of the liquid hydrogen tankers is estimated to be around 700,000-900,000 \$/unit, while for a tube trailer the cost is around 500,000-600,000 \$/unit, respectively. Especially tube trailers have a very large cost range as the tank types and payload depend on the pressure level. The capital cost per payload is around 600-1,000 \$/kg for tube trailers and 100-300 \$/kg for LH₂ trailers. Thus, generally in terms of capital cost, transporting LH₂ is less expensive than transporting gaseous hydrogen taking into consideration the amount of hydrogen transported per unit (Li et al., 2020; U.S. Department of Energy, 2015). In the cost model presented in *Section 5*, hydrogen transport with a pressurized gas container solution is considered. The reference for the cost of a hydrogen container is taken from the work by (Hurskainen & Ihonen, 2020) and it is similar to the cost presented above for tube trailer solutions. Note, however, then comparing the transporting of LH₂ vs. compressed gaseous hydrogen, this does not include the costs related to liquefaction.

2.7.2 HRS costs

Specific hydrogen refuelling station costs presented here are the dispensing related costs that include hoses, pumps, and evaporators, while storage related costs are not discussed in this section. The case study in *Section 5* includes estimates of the total dispensing cost of an HRS based on the HDRSAM-tool¹⁹.

The U.S. Department of Energy (2015) has estimated the uninstalled costs of dispensers. A dispenser with one hose that dispenses gaseous hydrogen at 700 bar costs around 55,000 € in 2020 and 37,000 € when there is a well-established hydrogen market. The U.S. Department of Energy (2015) also has an estimate for the liquid hydrogen pumps for terminals and fuelling that is based on information from manufacturers. The uninstalled cost for a liquid hydrogen pump where LH₂ is pumped to an evaporator at the HRS was said to be \$75,000 in 2020 at 430 bar and with the flow rate of 100 kg/h. The ultimate target for the pumps at this pressure level and flow rate is \$65,000 or ~60,000 €. The pump costs at 900 bar and a similar flow rate of 100 kg/h are \$650,000 or ~596,000 € for 2020 and the costs should ultimately decrease to \$200,000 or ~180,000 € with a well-established hydrogen market. The assumed lifetimes for pumps are 10 years or ultimately more than 10 years (U.S. Department of Energy, 2015).

2.7.3 Liquid hydrogen on-board tank costs

On-board liquid hydrogen storage tank costs vary greatly per source but generally fall between 100-1,000 €/kg(H₂). The great variation in cost is due to different system characteristics such as capacity of the tank but also due to the market being non-established and therefore difficult to forecast. Pressurized on-board hydrogen storage is estimated to cost more than liquid hydrogen storage because of the smaller volumetric capacity and increased required tank durability due to high pressure.

Ahluwalia et al. (2023) have estimated the cost of on-board liquid hydrogen storage for heavy-duty trucks. The cost depends on number of tanks, capacity, size, configuration, and insulation thickness. The projected costs vary between \$174–898 per kg of useable H₂. The lowest cost of on-board LH₂ storage (~170-180 \$/kg) is achieved when the useable H₂ per system is ~85-90 kg and the highest cost (~800-900 \$/kg) when the useable H₂ is ~21-24 kg per system. All costs are projected for 100,000 units per year.

A study report published in 2020 by Roland Berger has estimated the total costs of ownership (TCO) for fuel cell electric vehicles (FCEVs). These costs include estimates for on-board liquid hydrogen tanks for heavy-duty vehicles. The on-board costs for liquid hydrogen are estimated to be 114-368 €/kg(H₂) in 2023 and 76-245 €/kg(H₂) in 2030. The lowest estimates are for mass production and the higher cost is the estimate for a niche market. For gaseous hydrogen storage at 700 bar, the on-board costs are estimated to be around 2-3 times higher than for liquid hydrogen.

¹⁹ <https://hdsam.es.anl.gov/index.php?content=hdsam>



Photo: Joakim Honkasalo, Unsplash

3 Hydrogen losses in liquid hydrogen supply chain

As hydrogen is an indirect greenhouse gas²⁰, its release to the atmosphere from the hydrogen supply chain should be minimized. The global warming potential of hydrogen is approximately a third of fossil methane on a kg-to-kg basis but unnecessary release of hydrogen to the atmosphere could reduce the climate benefit gained from using renewable hydrogen. Therefore, avoiding hydrogen release to the atmosphere is not only important from a safety point-of-view - but also from an environmental point-of-view (International Energy Agency (IEA), 2022).

Concerning storage of liquid hydrogen, focus on hydrogen release to the atmosphere is highly applicable due to boil-off. Now, minimizing boil-off is easier with large-scale storage where the surface-area-to-storage-volume-ratio is minimized. However, even large-scale storage options have some boil-off and especially transferring liquid hydrogen from a tank or vehicle to another likely results in some hydrogen losses. Therefore, instead of releasing the hydrogen to the atmosphere to relieve pressure, the released hydrogen could be captured and utilised e.g., as a feed gas for a fuel cell like Linde's FuelTech hydrogen fuelling station mentioned above utilising boil-off in the cooling of the fuelled compressed gaseous hydrogen (Cardella, 2019).

²⁰ Hydrogen has the property to interact with other gases in the atmosphere affecting the concentration of methane, ozone, and water vapour, and there is evidence that this impact is higher than earlier thought.

4 Liquid hydrogen in the Nordic countries

In the Nordic countries, electricity production is mainly based on renewable sources making production of green hydrogen highly feasible. This aspect is in favour of creating a liquid hydrogen product for other markets where renewable energy and green hydrogen might not be available in large quantities.

The Nordic countries have limited use of liquid hydrogen today, but many initiatives are ongoing. Norway has the most activities in this area. In Finland, Sweden, Denmark, and Iceland there are no significant market demand for liquid hydrogen production, but the potential is high. For instance, Denmark is well connected to Central Europe via roads, which creates an opportunity for exporting liquid hydrogen to Central Europe. Finland and Sweden have a lot of ships and on-road transport, which can potentially create a good market demand for liquid hydrogen if the fuel cost becomes competitive.

Hydrogen is a good solution for transport missions which require a longer range between refuelling and have high power consumption. Liquid hydrogen has been used in ships where the power demand of the system is high, and the process can be controlled and predicted well. Marine transport vessels are not as sensitive to load capacity as vehicles for road transport, which often are struggling with payload capacity issues when it comes to the new zero emission drivelines. Other suitable applications would be long-haul trucks, construction equipment, trains, and airplanes.

A collaboration called H2Accelerate is working on accelerating the adoption of hydrogen for on-road use²¹. The collaboration comprises members from hydrogen producers, infrastructure operators, and vehicle manufacturers. This is only one example of many projects, collaborations, and initiatives that are boosting the hydrogen market in Europe and in the Nordic countries. The aim is to deploy refuelling stations that are capable of offering both gaseous and liquid hydrogen.

Liquid hydrogen is tested for on-road transport by some manufacturers in Europe. These trucks could be traveling on Nordic roads as there is frequent on-road transportation of goods within the European countries. Daimler truck is one of these manufacturers testing a truck with two 40 kg liquid hydrogen tanks. The objective is to reach an operating range up to 1,000 km. Series production is planned for the second half of the decade (Daimler, 2022).

As the available liquid hydrogen transport solutions for road transport are designed for European or Northern American roads, a unique solution with an optimized design would be preferred to maximize the amount of liquid hydrogen delivered in the Nordics, especially Sweden and Finland, as higher truck payloads are allowed. The delivery solution with the most potential would be a configuration of connected liquid hydrogen tanks or trailers to maximize the transported capacity. Denmark, Norway, and Iceland do not allow for larger container configurations as in Finland and Sweden, and therefore, a compatible solution with Europe and EU countries is more suitable for liquid hydrogen transportation.

²¹ <https://h2accelerate.eu/>

4.1 Finland

4.1.1 Liquid hydrogen projects

Currently, there are no ongoing projects regarding liquid hydrogen in Finland. Woikoski imported LH₂ from Europe to its customers earlier, but nowadays there is no demand for liquid hydrogen in Finland. Woikoski has equipment for producing helium and this equipment could be used to produce liquid hydrogen (with some modifications). Liquid hydrogen study has been made for the liquefaction of by-product hydrogen (scale was found to be too small). Although, Plug Power is planning on investing in three renewable hydrogen production plants in Finland which would also include a hydrogen liquefaction plant of generation capacity of 85 tpd in Kokkola²².

4.1.2 Liquid hydrogen delivery

In Finland, liquid hydrogen could be transported either with A-double, B-link, or semi-trailer configurations as discussed in Next Wave Deliverable 2.4 - Hydrogen transport from large-scale production points to Nordic consumers²³. The A-double configuration with a maximum length of 34.5 meters would allow the connection of two 45 ft containers. The weight left for the hydrogen and containers would be approximately 40 tonnes since the empty vehicle weight, including trailers, is around 20 tonnes and the maximum weight for ADR vehicles is 60 tonnes as explained in Next Wave Deliverable 2.2. Therefore, the maximum amount of liquid hydrogen transported could be around 8 tonnes in case the two containers would weigh around 32 tonnes. This is an estimate based on the weight of two 40 ft containers with a liquid nitrogen shield by Linde designed for cryogenic liquid helium transportation²⁴. Linde also offers a similar 40 ft container solution for the transport and storage of liquid hydrogen, Hylics, which is assumed to weigh approximately the same as the container meant for helium (Decker, 2019).

Although, 45 ft containers are likely to weigh more than 40 ft container tank solutions. In addition, the weight of the two containers would also depend on whether the tanks are swappable tanks or just used for the delivery of LH₂. Swap-tanks likely require better protection against boil-off effects than tanks used solely for delivery since they are designed to be left at the HRS. Regardless

²² <https://www.sttinfo.fi/tiedote/plugin-power-together-with-its-partners-plans-to-develop-three-green-hydrogen-production-plants-in-kokkola-porvoo-and-kristinestad?publisherId=6981-9483&releaseId=69983235&lang=en>

²³ https://www.nordichydrogenpartnership.com/wp-content/uploads/2021/11/Next-Wave-D2_4-Large-scale-H-transport.pdf

²⁴ https://www.linde-engineering.com/en/images/UN-portable-tank-for-helium_tcm20-281285_tcm19-588803.pdf



Photo: Julius Jansson, Unsplash

of the type of tank, a maximum of ~7-8 tonnes could be transported with a configuration of two 45 ft liquid hydrogen tanks.

The B-link configuration allows a larger weight of 68 tonnes but has room for only two 40 ft containers. Assuming a similar container weights as for the A-double connection, the maximum allowed amount of liquid hydrogen transported with a double 40 ft container connection would weigh around 16 tonnes. Although, the maximum amount of hydrogen transported could be around 6-7 tonnes as for the A-double configuration if the standard 40 ft ISO frame would be used.

The longer allowed semi-trailer length of maximum 23 m would allow for a liquid hydrogen container length of 19.3 m (~63 ft) in Finland. They are not available at the market and therefore a unique design would be required to maximize the amount of LH₂ transported per truck (Ihonen, Viik, et al., 2021). Although, assuming a longer semi-trailer of 19.3 m was available, a maximum of approximately 5.5 tonnes of LH₂ could be transported based on the dimensions given for road transport liquid hydrogen tanker trailers above with a height of 4.4 m that is the maximum allowed height for road transportation in Finland. This is less than the ~6-7 tonnes of LH₂ that could be transported with connected container or semi-trailer configurations. Therefore, an extra long semi-trailer configuration does not necessarily pay off.

4.2 Sweden

4.2.1 Liquid hydrogen projects

Currently there are no known plans regarding liquid hydrogen in Sweden. Although, Sweden could have a potential of having joined delivery chain of LH₂ with Finland because of the similar road transport regulation, as discussed earlier.

4.2.2 Liquid hydrogen delivery

In Sweden, different roads have different requirements on payloads. BK1 roads allow for 64-tonne payloads and BK4 roads allow up to 74-tonne payloads. BK4 roads that allow for higher payloads make up around 20% of the public roads by 2019. Very long semi-trailers of length 24 m are allowed. Vehicle configurations are discussed in more detail in Next Wave Deliverables 2.3²⁵ and 2.4. Although, an update regarding the information present in the previous Next Wave deliverables is that combined vehicle lengths of 34.5 m are now allowed in Sweden²⁶.

Both Finland and Sweden allow high payloads and the transport of very long semi-trailers on roads. The maximum weight for vehicles in both Sweden and Finland is quite high: 64-74 tonnes for Sweden and 60-68 tonnes for Finland depending on the connection type. Further information is given in Next Wave Deliverable 2.2. Therefore, a semi-trailer solution for liquid hydrogen transport in Finland and Sweden would combine these requirements and have a maximum weight of 64 tonnes making the semi-trailer solution suitable for both Finnish and Swedish roads while maximizing the amount of liquid hydrogen transported. In addition, a configuration with two 40 ft or 45 ft sized liquid hydrogen tanks would be plausible size-wise.

Available payload for the two containers to transport liquid hydrogen would be around 40 tonnes as the empty vehicle weight for trucks that include trailers is around 20 tonnes. The maximum capacity of transported liquid hydrogen with two 40 ft containers would be around 6 tonnes of liquid hydrogen (Decker, 2019). This would not exceed the maximum weight limit of 64 tonnes since two liquid hydrogen containers would weigh around 32 tonnes. If instead two 45 ft containers were used for hydrogen transportation, around 7-8 tonnes of liquid hydrogen could be transported.

²⁵ https://www.nordichydrogenpartnership.com/wp-content/uploads/2021/06/Next-wave-D2_3-Nordic-transport-regulations-for-H.pdf

²⁶ https://www.riksdagen.se/sv/dokument-och-lagar/dokument/svensk-forfattningssamling/trafikforordning-19981276_sfs-1998-1276/

4.3 Norway

4.3.1 Liquid hydrogen projects

In Norway, several LH₂-related projects are being kicked off or are on-going, including:

- In 2017/2018, Moss Maritime developed a 9,000 m³ LH₂ bunker vessel concept in the Joint Industry Project *Ship transport solution for liquefied hydrogen* together with Equinor, Wilhelmsen, and DNV. As a follow up, Moss Maritime, in collaboration with SINTEF Energy Research and SINTEF Industry, is now conducting the HyLaSST project (*Hydrogen Large Scale Ship Transport*), a 3-year (2021-2023) project granted partial funding by the Research Council of Norway where the objective is to develop a containment technology for large scale LH₂ ship transport, for ships with similar capacity as large LNG carriers.
- *Development and validation of a new magnetocaloric high-performance hydrogen liquefier prototype* is a 5-year Clean Hydrogen Partnership (EU) project under the HORIZON-JTI-CLEANH2-2022-1 call with Institute for Energy Technology (IFE) as coordinator and 12 (+1 associate) partners. TRL3 (start) - TRL5 (end).
- *HYLICAL – Hydrogen Liquefaction with CALoric Materials* is another project coordinated by IFE. In this project, which is supported by the Research Council of Norway, IFE collaborates with two foreign partners and five national industrial partners. TRL2 (start) - TRL4 (end).
- *HYDROGENi – Norwegian research and innovation centre for hydrogen and ammonia* is a new FME (Centre for Environment-friendly Energy Research) in Norway that was kicked off late 2022 coordinated by SINTEF and gathering all the major research institutions on hydrogen in Norway (SINTEF, NTNU, IFE, UiO, USN, and UiT) as well as a range of industrial partners (<https://hydrogeni.no>). Here, LH₂-related activities such as "Liquid H₂ technologies" under RA2 (Transport and Storage) and "Material integrity" under RA4 (Safety and material integrity) are planned.

As part of its services being the National Industry Association for Hydrogen and Ammonia, NHF has gathered an overview of planned and existing hydrogen and ammonia projects in Norway – denoted *The Norwegian Hydrogen Landscape*²⁷.

The Norwegian Hydrogen Landscape contains a detailed overview of Norwegian renewable and low-carbon hydrogen and ammonia projects, both within production, consumption, research and development (R&D), and technology scale-up. Also, the overview contains a map of each project's geographical location as well as estimates on production capacity.

²⁷ <https://www.hydrogen.no/faktabank/det-norske-hydrogenlandskapet>



As the Norwegian hydrogen industry is under rapid development, it may be difficult to grasp and maintain all initiatives and projects. However, the intention is that the overview shall be updated regularly to ensure that it represents an as-exact picture of the status of the industry as possible – also including future liquid hydrogen projects and initiatives.

One major milestone was reached in Norway when the maiden hydrogen voyage of the first liquid hydrogen ferry, MF Hydra, was celebrated March 31, 2023. The 82.4 m long ferry with a capacity of 299 passengers and 80 cars is in daily services at the Hjelmeland-Nesvik-Skipavik ferry connection (Riksvei 13) south-west in Norway. The hybrid ferry might be powered both battery-electric (battery capacity 1.5 MWh) and fuel cell-electric by means of a PEM fuel cell capacity of 400 kW and a LH₂ storage of 4 tonnes. In fuel cell-mode, up to 90% of the needed power for the ship is provided by the fuel cell while the batteries are supporting peak loads.

When operated in fuel cell-mode, MF Hydra consumes about 150 kg of liquid hydrogen per day. In the absence of liquid hydrogen production in Norway, 3.2 tonnes of liquid hydrogen are trucked in from Leuna, Germany every 3rd week (Østvik, 2021). Now, liquid hydrogen production sites have been planned at several locations in Norway, e.g., at Mongstad at the south-west coast of Norway, some 65 km north of Bergen and some 310 km north of Viganeset where MF Hydra is bunkering liquid hydrogen. Currently, however, there is no decision made when or if liquid hydrogen actually will be produced at Mongstad or any other place in Norway.

4.3.2 Liquid hydrogen delivery

As discussed in the Next Wave Deliverable 2.3 - Nordic transport regulations for large-scale hydrogen transport²⁸, Norwegian roads are divided into categories based on permitted weights and dimensions. The maximum vehicle weight is 50-60 tonnes while the lengths vary from 12 m to 19.5 m. This would mean that liquid hydrogen transport solutions suitable for large-scale transport in Sweden and Finland would not be compatible in Norway because of the stricter requirements. In addition, the transportation of dangerous goods (incl. hydrogen) does not allow for the use of 45 ft containers in Norway. Therefore, a 40 ft container configuration would be required for liquid hydrogen transport. A 40 ft container configuration for liquid hydrogen transport is compatible also for European roads. Therefore, a similar solution as in Europe for liquid hydrogen delivery could be used in Norway. The amount of liquid hydrogen transported with a 40 ft container configuration would be around 3 tonnes.

²⁸ https://www.nordichydrogenpartnership.com/wp-content/uploads/2021/06/Next-wave-D2_3-Nordic-transport-regulations-for-H.pdf



Photo: Rory Hennessey, Unsplash

4.4 Iceland

4.4.1 Liquid hydrogen projects

In Iceland there are currently no plans regarding liquid hydrogen. Although, abundant and cheap renewable energy presents an opportunity for possible liquid hydrogen production.

4.4.2 Liquid hydrogen delivery

In Iceland, a single 45 ft container with a maximum weight of 30 tonnes could be used to transport liquid hydrogen. Therefore, large-scale liquid hydrogen transportation as in Finland and Sweden is not possible. The vehicle configurations are discussed in more detail in Next Wave Deliverable 2.3. In addition, Iceland is isolated with no road connections to any of the other Nordic countries which is why standard solutions compatible to European roads would likely be used for transporting liquid hydrogen. This means that around 3-4 tonnes of liquid hydrogen could be transported per truck in Iceland.

Looking forward, however, possibly a more interesting liquid hydrogen delivery solution for Iceland would be to transport liquid hydrogen by a carrier vessel, such as the Suiso Frontier, to mainland Europe.



4.5 Denmark

4.5.1 Liquid hydrogen projects

In Denmark, a project consortium is working on a project led by Ballard to develop a heavy-duty fuel cell module for maritime applications, that will utilize cryogenic liquid hydrogen as the fuel. The project will identify and develop technical solutions for storing and using liquid hydrogen safely and efficiently on-board on a modular fuel cell system (Ballard Europe).

In addition, the proximity to Central-Europe, especially Germany, could be beneficial for Denmark in future LH₂ related projects. Transporting energy as liquid hydrogen from Denmark to Germany could potentially decrease the load of the electricity grid which could already be a possible bottleneck because of the extensive wind power production in Denmark but also the renewable electricity production in Germany.

4.5.2 Liquid hydrogen delivery

Denmark would most likely benefit the most from utilising solution compatible for European roads because of the well-established connection of Denmark and Central Europe even though slightly larger payloads would be allowed with certain vehicle types than in all EU countries. A compatible EU-wide solution utilises either a 40 ft or a 45 ft tank or semi-trailer vehicle configuration that could transport around 3-4 tonnes of liquid hydrogen per truck.





Photo: Mika Luoma, Unsplash

5 Case study – Delivery of hydrogen in Finland

5.1 Delivery cost analysis

The case study on the delivery of hydrogen in Finland introduced in this work presents an update to the previous cost model introduced in Next Wave Deliverable 2.5 - Detailed analysis for large-scale hydrogen transport in Finland²⁹. This case study analyses the total delivery costs of the transported hydrogen from production to dispensing. The aim is to compare the costs of delivering hydrogen as a liquid and compressed gas. As in Next Wave Deliverable 2.5, a similar approach is used in the analysis as in the previous work by Hurskainen & Ihonen (2020).

This delivery cost analysis will consider the HRS criteria set in the Alternative Fuel Infrastructure Regulation (AFIR) which was initially proposed in 2021. A provisional agreement regarding AFIR was reached between the Council and the Parliament on March 28, 2023. Despite earlier proposals, the provisional agreement does not include liquid hydrogen. Gaseous hydrogen at 700 bar is required at hydrogen refuelling stations every 200 km along the TEN-T core network and in every urban node with a minimum capacity of at least 1,000 kg/day. In Finland, a total of ~10 HRS stations are needed to fill the minimum requirements listed in AFIR.

²⁹ https://www.nordichydrogenpartnership.com/wp-content/uploads/2022/06/Next-Wave-D2_5-Detailed-analysis-for-large-scale-H-transport-in-Finland.pdf

The costs of hydrogen delivery are determined in three scenarios: two for compressed gas hydrogen (CGH₂) and one for liquid hydrogen. The two scenarios for CGH₂ are a semi-central scenario where hydrogen is produced from additional electrolyser capacity at an industrial site, compressed, and transported to the HRS, and an on-site hydrogen production scenario in which the hydrogen is produced, compressed, and dispensed at the site of the HRS itself. The scenario including LH₂ is also a semi-central scenario where hydrogen is produced from additional electrolyser capacity at an industrial site, liquefied, and distributed to the HRS. On-site LH₂ production scenario is not included in this delivery cost estimation due to the criteria laid out in AFIR. The latest developments of AFIR do not include liquid hydrogen dispensing requirements and therefore only gaseous hydrogen dispensing at 350 bar will be considered for heavy-duty vehicles. Therefore, the benefit of liquefaction should come from the transport to the HRS alone as on-site hydrogen liquefaction only to dispense it as a compressed gas will not be beneficial. This again is mainly a result of the fact that liquefaction is an energy-intensive process. The three different scenarios are graphically illustrated in *Figure 4*.

Two hydrogen demand levels are considered in this cost model. The first demand level is based on the demand required in the Alternative Fuel Infrastructure Regulation (AFIR) which is 1 tonne H₂/day per HRS. The second hydrogen demand level modelled is 5,000 kg H₂/day per HRS. This is based on the consideration that hydrogen would be produced as additional electrolyser capacity semi-centrally together with other industrial production. An in-depth explanation regarding the demand levels and by-product hydrogen in Finland is given in connection with the case study presented in the Next Wave Deliverable 2.5. Although, on-site electrolysis is not analysed with the higher demand level (5,000 kg H₂/day) because this is seen as too large demand to produce on-site but instead connected to an industrial site.

Even though liquid dispensing is not considered as a part of AFIR, it could still be beneficial in applications that require heavy machinery. This applies to mining, as an example. The scale is different compared to heavy-duty vehicles: the power required to drive heavy machinery is much larger and there is much space for liquid hydrogen storage.

Scenario 1: CGH₂ produced semi-centrally by electrolysers and transported to the HRS

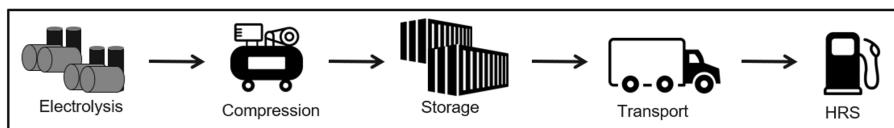

Scenario 2: CGH₂ produced on-site by an electrolyser at the HRS

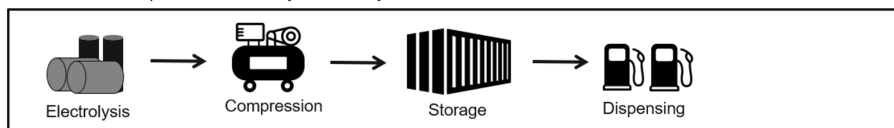

Scenario 3: LH₂ produced semi-centrally by electrolysers and transported to the HRS

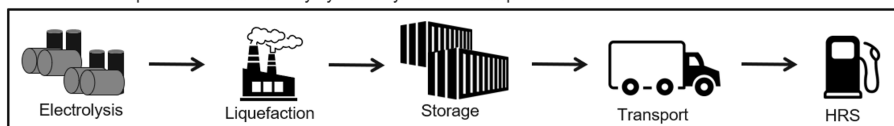

Figure 4. Considered scenarios in the case study.

5.2 Cost model structure

The general structure of the delivery cost model is presented here. The cost model consists of different parts that all contribute to the final delivery cost of hydrogen. These parts are specific costs per delivery component, such as hydrogen production and trucking costs. As stated above, a similar approach is used as in Next Wave Deliverable 2.5 in which a method by (Hurskainen & Ihonen, 2020) is used. The general cost structure is presented in Eq. 1:

$$SC_{delivery} = SC_{prod} + SC_{processing} + SC_{trucking} + SC_{dispensing} + SC_{storage} + SC_{liq} \quad Eq. 1$$

where the specific total delivery cost ($SC_{delivery}$) consists of hydrogen production costs (SC_{prod}), hydrogen processing costs, including compression, ($SC_{processing}$), trucking costs ($SC_{trucking}$), dispensing costs ($SC_{dispensing}$), storage costs ($SC_{storage}$), and liquefaction costs (SC_{liq}).

All investment costs (IC) are annualized using the capital recovery factor (CRF):

$$CRF = \frac{i \cdot (1 + i)^n}{(1 + i)^n - 1} \quad Eq. 2$$

where i is the interest rate and n is the lifetime in years. A standard interest rate of 8% is used unless stated otherwise.

The investment costs IC are then further multiplied with the CRF to get the annual investment costs IC_{annual} :

$$IC_{annual} = CRF \cdot IC \quad Eq. 3$$

Some of the investment costs are scaled to the appropriate size with a scaling function:

$$IC_2 = IC_1 \left(\frac{C_2}{C_1} \right)^{sf} \quad Eq. 4$$

where IC_2 is the new obtained investment cost (€), IC_1 is the investment cost of the reference size, C_1 is the reference capacity, C_2 is the capacity of desired size, and sf is the scaling factor.

All the costs are calculated in Euro (EUR, €). United States dollar (USD, \$) is converted into EUR with a conversion rate of 1 USD = 0.92 EUR. Canadian dollar (CAD, \$) are converted into USD with a conversion rate of 1 CAD = 0.75 USD.

5.3 Hydrogen production

The delivered hydrogen is produced through alkaline electrolysis. Alkaline electrolysis is used in the calculations because it is already commercial and used in large industrial-size applications. Therefore, alkaline electrolysis is considered best suited for hydrogen production units in the MW-scale. The assumed output pressure of the produced hydrogen is 20 bar.

Electrolyser sizing is considered separately for both the semi-central and on-site approaches. For the liquid and compressed gas hydrogen delivery scenarios, the electrolyser costs are assumed identical except for the on-site hydrogen production. For the semi-central hydrogen production, two additional alkaline electrolyser capacity extensions are considered that produce a combined amount of hydrogen equivalent to the total hydrogen demand.

There are different approaches to sizing the electrolyser for the hydrogen demand. The electrolyser size and use case affect the utilisation rate (*UR*). The utilisation rate is considered to be high (80%) for the extended electrolyser capacity connected to a pre-existing industrial process because of high industry demand. Although, for the on-site hydrogen production, a lower utilisation rate of 40% is considered. Both semi-central and on-site hydrogen production have assumed full load hours (*FLH*) at 8,700 h/year.

Proost (2019) investigated the state-of-art CAPEX values for PEM and alkaline electrolysers. According to the study, a CAPEX of 750 €/kW is a realistic estimate for single stack alkaline electrolysis systems up to 2 MW. For larger systems of multiple megawatts, a CAPEX discount is expected both for alkaline and PEM electrolysers. The estimates go as low as 400 €/kW for 100 MW systems (Proost, 2019). In this analysis, a CAPEX value of 750 €/kW is used for on-site electrolysis because it is a system of size <10 MW and therefore the CAPEX discount is not expected to kick in at this stage. For semi-centralized hydrogen production, the assumed CAPEX is 500 €/kW. This is because the CAPEX is assumed to decrease when the size of the electrolysis system increases to 10-100 MW but it is not expected to go below this value. Note, however, the estimates given in literature tend to be more optimistic than the estimates given by the industry. Note also that several hundred MW electrolyser systems do not currently exist and are thus not yet deployed. Therefore, actual data is required on what the electrolyser costs for large systems are going to look like in the future.

The considered electrolyser capacities and capital investment costs are presented in *Table 3*. An important note is that in the scenario with on-site hydrogen production, the electrolyser is oversized due to low utilisation rate (*UR*).

Several assumptions are made for the electrolysis system. The energy consumption used for all system sizes is 55 kWh/kg H₂. The electricity price is 30 €/MWh for semi-central hydrogen production and for on-site production with the larger demand level. The electricity price is assumed 50 €/MWh for the on-site production for the lower demand level. All electrolysis systems have a lifetime of 15 years and have the fixed operation and maintenance cost of 5%.

The specific hydrogen production cost (SC_{prod}) is calculated with the following equation:

$$SC_{prod} = \frac{IC_{prod} \cdot (CRF_{prod} + FC_{prod}) + Electricity\ price \cdot UR \cdot FLH \cdot Capacity}{Capacity \cdot FLH \cdot UR \cdot \frac{1}{\eta_{electrolysis}}} \quad Eq. 5$$

where IC_{prod} is the investment cost of the electrolyser capacity, CRF_{prod} is the capital recovery factor of the electrolyser, FC_{prod} are the fixed cost of operation and maintenance as a percentage of the investment cost, and $\eta_{electrolysis}$ the efficiency of the electrolysis system in kWh/kg H₂.

Table 3. Electrolyser capacities and CAPEX values

	On-site (1,000 kg/day, UR = 40%)	Semi-central (1,000 kg/day, UR = 80%)	Semi-central (5,000 kg/day, UR = 80%)
Electrolyser capacity (MW)	6	15+15	75+75
CAPEX (€/kW)	750	500	500

5.4 Processing/Compression

As discussed above, in this model study the hydrogen is stored physically at the HRS as compressed hydrogen gas in a hydrogen container, in a compressed hydrogen tank, or the refuelling cascade storage of the HRS. Thus, a compressor is required at the production site to compress the hydrogen to the desired transport pressure level. Liquid hydrogen is not compressed at the production site but instead liquefied.

The processing costs include the compressor costs and site costs (e.g., costs for housing, piping, engineering...). Only gaseous hydrogen includes costs related to compression but both gaseous and liquid hydrogen processing costs include site costs.

Costs related to compression include a lot of uncertainty. The general understanding is that compression includes significant investment costs.

Gaseous hydrogen is compressed to the appropriate pressure level with a compressor. For the hydrogen container and the on-site storage tank the desired pressure level is 200 bar. Therefore, the produced hydrogen is compressed from 20 bar to 200 bar.

Before calculating the investment costs of the compressor, the required compressor power must be determined. The method and equations used are based on the technical brief regarding hydrogen compression (Khan et al., 2021).

When determining the hydrogen compressor power, first, the number of compression stages is calculated. The number of compression stages, N , is calculated as follows:

$$N = \frac{\log\left(\frac{P_{disc}}{P_{suc}}\right)}{\log(x)} \quad \text{Eq. 6}$$

where P_{disc} is the discharge/outlet pressure (bar), P_{suc} is the suction/inlet pressure (bar), and x is the compression ratio. For P_{disc} a value of 200 bar is used, for P_{suc} 20 bar, and for x a ratio of 2.4.

After N is determined, the following equation is used to determine the power of the compressor, $P_{multi\ stage}$, assuming an isentropic multistage process:

$$P_{multi\ stage} = N \left(\frac{k}{k-1}\right) \left(\frac{Z}{\eta_{isen}}\right) T_{suc} (q_M) R \left[\left(\frac{P_{disc}}{P_{suc}}\right)^{\left(\frac{k-1}{Nk}\right)} - 1 \right] \quad \text{Eq. 7}$$

where k is the specific heat under constant pressure to specific heat under constant volume ($k = \frac{c_p}{c_v} = 1.41$), Z is the average compressibility factor, T_{suc} is the suction/inlet pressure (K), q_M is the molar flow rate (mol/s), and R is the universal gas constant (8.314 J/K mol). The values used for Z and T_{suc} are 1.05, and 315.17 K, respectively. The molar flow rate q_M is calculated base on the daily demand.

Last, the multistage power of the compressor is divided by the motor efficiency ($\eta=95\%$) to get the actual compressor power.

Now, the compressor costs can be determined. The investment costs ($IC_{compression}$) of the compressor are calculated as follows:

$$UC = \text{Base value} \cdot P_{actual}^f \quad \text{Eq. 8}$$

$$IC_{compression} = UC \cdot IF \quad \text{Eq. 9}$$

where the uninstalled costs UC of the compressor depend on the compressor actual power (P_{actual}), a Base value, and a scaling factor f given in the technical brief. The investment cost $IC_{compression}$ depends on the uninstalled costs UC and the installation factor IF . The Base value, the scaling factor f , and the installation factor IF vary depending on whether the compressor is used on-site or at a centralized plant. The values used are presented in Table 4.

Table 4. Values used to determine the total investment cost of compression (Khan et al., 2021)

	Base value	Scaling factor f	Installation factor IF
On-site	63,684.6	0.4603	1.3
Semi-central	3,083.3	0.8335	2

The site costs include additional costs related to the site, including costs for piping, buildings, and engineering. Semi-central hydrogen production systems are assumed to be connected to pre-existing industrial sites where necessary infrastructure is already present. However, on-site production does not have already existing infrastructure attached to it. Therefore, the following relation is used to determine the site investment costs (IC_{site}) for on-site hydrogen processing:

$$IC_{site} = 0.75 \left(\frac{\text{Hydrogen demand} \left[\frac{\text{kg}}{\text{day}} \right]}{1800} \right)^{0.5} \quad \text{Eq. 10}$$

After the investment costs of compression and siting are determined, the specific cost related to hydrogen processing can be calculated. The specific processing cost ($SC_{processing}$) is obtained by multiplying the investment costs with a capital recovery factor and dividing the result by the annual delivered useable hydrogen:

$$\begin{aligned} SC_{processing} &= SC_{compression} + SC_{site} \\ &= \frac{IC_{compression} \cdot CRF_{compression}}{\text{Annual delivered useable hydrogen}} + IC_{site} \end{aligned} \quad \text{Eq. 11}$$

Photo: Annett99, Unsplash



5.5 Trucking

Trucking costs are calculated for both gaseous and liquid hydrogen. Although, for on-site production, no trucking costs are considered. Otherwise, the trucking cost calculations for liquid and gaseous hydrogen are identical.

The trucking costs are calculated by initially determining the required number and investment costs of required trucks and trailers. For gaseous hydrogen, a configuration of two 40 ft hydrogen containers is considered. Each of the 40 ft containers consist of two 200 bar steel bottle ISO 20 ft containers as in (Hurskainen & Ihonen, 2020). In total, the two 40 ft container configuration adds up to a total payload of 800 kg per truck. For liquid hydrogen, one or two liquid trailers are considered for the transportation of liquid hydrogen depending on the hydrogen demand level. In the case of hydrogen transport according to the AFIR-demand (1,000 kg/day), only one 40 ft liquid hydrogen trailer is considered. However, with the larger demand level (5,000 kg/day), a combination of two 40 ft liquid hydrogen trailers is considered. The payload of one liquid hydrogen trailer is 3,000 kg as with the trailers provided by Linde (Decker, 2019).

The investment cost for the truck is the same for both gaseous and liquid hydrogen, but the trailer costs differ. The costs for the truck and containers, together with the assumptions used regarding trucking, are the same as used in the work by Hurskainen & Ihonen (Hurskainen & Ihonen, 2020). For the liquid hydrogen trailer, an investment cost per trailer of 800,000 € is used.

As for the average driving speeds of the delivery, similar values are used as in (Hurskainen & Ihonen, 2020). For distances less than 150 km, 65 km/h is used as the average speed. Similarly, 72 km/h is used for distances between 150-300 km, and 77 km/h when the distance is more than 300 km.

As for the calculations in Next Wave Deliverable 2.5, the amount of transported hydrogen containers required is three times the used configuration. This is a result of one container combination being transported, the second acting as a storage at the production site and the third at the HRS. Only one liquid hydrogen trailer configuration of one or two trailers is required because separate liquid hydrogen storages are assumed at the production and HRS ends. The loading time is longer for the liquid trailer, three hours for loading and one hour for unloading. For gaseous hydrogen, the assumed loading times are one hour at each end.

The specific delivery cost of trucking ($SC_{trucking}$) is calculated as follows:

$$SC_{trucking} = \frac{IC_{trucking} \cdot CRF_{trucking}}{\text{Annual delivered useable hydrogen}} + SC_{trucking,O\&M} + SC_{trucking,fuel} + SC_{trucking,personnel} \quad \text{Eq. 12}$$

where the trucking costs consist of investment costs of trucks and trailers ($IC_{trucking} \cdot CRF_{trucking}$), operation and maintenance costs ($SC_{trucking,O\&M}$), fuel costs ($SC_{trucking,fuel}$), and labour costs ($SC_{trucking,personnel}$). The equations that further explain how the trucking costs are determined are presented in the *Appendix*.

5.6 Liquefaction

After producing hydrogen through electrolysis, the hydrogen is liquefied before delivery. Gaseous hydrogen delivery scenarios do not include this cost. For hydrogen liquefaction, plants of either 15 tpd or 30 tpd are considered, depending on the demand level. For the smaller demand (AFIR only) two 15 tpd plants are considered, and for the larger demand (5,000 kg/day/HRS) two 30 tpd liquefaction plants are considered. Two separate liquefaction plants are considered instead of one large to ensure secure and consistent production.

The liquefaction plant capacities and deployment are not only relevant for filling the hydrogen demand in the scenarios presented in this case study, but also from a broader perspective. According to the most recent provisional agreement regarding the revision of the Renewable Energy Directive (2018/2001), a minimum requirement of 5.5% of advanced biofuels (mostly derived from non-food-based feedstocks) and renewable fuels of non-biological origin (RFNBOs) in the share of renewable energies supplied to the transport sector must be fulfilled by 2030. This target includes a 1% minimum requirement for RFNBOs (include renewable hydrogen but also other hydrogen-based synthetic fuels). Considering that the energy consumption of the Finnish transport sector was 170,000 TJ in 2021³⁰ and hydrogen energy content is 120 MJ/kgH₂, around 40 tpd of hydrogen would be needed to fulfil the 1% requirement. Therefore, the scale of the hydrogen liquefaction plants of ~30 tpd is not far-fetched. In addition, liquid hydrogen could replace the share of the advanced biofuels in the fuel mix in case they are very expensive to produce.

Liquefaction cost estimates vary greatly. In 2019, the U.S. Department of Energy estimated the capital costs of a 27 tpd hydrogen liquefaction plant to be 160 million USD (Connelly et al., 2019). This estimate is, however, significantly lower than the investment costs given by Air Liquide in 2022 stating an investment of 250 million USD for a 30 tpd hydrogen liquefaction plant (Air Liquide, 2022). As a result, an *in-between* capital cost estimate of 200 million EUR for a 30 tpd hydrogen liquefaction plant is used in this study. A liquid hydrogen storage is assumed to be included as a part of this investment cost. Because the desired plant capacity is 15 tpd in the AFIR scenario instead of 30 tpd, a scaling function, Eq. 4, is used to determine the investment costs for a plant with a reduced capacity. A scaling factor of 0.8 is used.

Several assumptions are used regarding liquefaction. The liquefaction plants are assumed to be operating with high utilisation rates (90%) at a high fixed operating and maintenance cost of 4% of the investment cost. The lifetime of the liquefaction plants is assumed to be 30 years. As stated previously, liquefaction is an energy-intensive process. The energy consumption is assumed to be the same for both sizes, 12 kWh/kg H₂. This is the case also for the electricity cost that is assumed 30 €/MWh for both scales. The energy consumption assumption is based on the estimations by (Cardella, 2019). As for the interest rate, a value of 8% is used.

³⁰ https://www.aut.fi/tilastot/liikenteen_energiankulutus

The specific cost of liquefaction (SC_{liq}) is calculated as follows:

$$SC_{liq} = \frac{IC_{liq} \cdot (CRF_{liq} + FC_{liq}) + EC_{liq}}{\text{Annual delivered useable hydrogen}} \quad \text{Eq. 13}$$

where IC_{liq} is the investment cost of the liquefaction plant, CRF_{liq} is the capital recovery factor of the liquefaction plant, FC_{liq} is the fixed operating and maintenance cost of the plant, and EC_{liq} are the electricity costs of the plant.

5.7 Storage

Hydrogen is stored in tanks both at the production site and at the HRS. All scenarios include a buffer tank at the HRS. At the hydrogen production site, bulk storage is considered in the semi-central scenario either in pressurized tanks or in bulk storage tanks for liquid hydrogen.

With on-site hydrogen production, a storage tank system size of the daily hydrogen demand is assumed to be located at the HRS. Similarly, a compressed hydrogen buffer storage system of size of the daily demand is considered at the location of the HRS for the semi-central scenario. A separate storage cost is not considered at the production end because of the assumptions of pre-existing infrastructure and hydrogen container storage. The liquid hydrogen bulk storage tank cost is not calculated as a part of the specific cost of storage because it is already included as a part of the liquefaction investment cost. However, a buffer storage for liquid hydrogen is considered at the HRS.

As in the gas phase study reported in Next Wave Deliverable 2.5, the cost level for the compressed hydrogen storage tank is set to 400 EUR/kg H₂ at 200 bar. There is some uncertainty related to this, but the level given in the gas phase study of Deliverable 2.5 was seen as a stable estimate. The cost is slightly lower than the target cost level given by the U.S. Department of Energy for 160 bar compressed stationary hydrogen storage (U.S. Department of Energy, 2015). Assumptions used for compressed hydrogen storage are a fixed operation and maintenance cost at 4% of the investment cost, and a lifetime of 20 years. The desired properties of the hydrogen tank affect maximum allowable pressure and therefore the type of the tank and the cost.

For liquid hydrogen storage, a semi-central storage system is considered. After liquefaction, the liquid hydrogen is stored before transported to the HRS. The liquid hydrogen is also stored as a liquid at the HRS, but his storage tank cost is not considered separately since it is already accounted for as part of the dispensing module of the HDRSAM modelling tool. For the demand level of 1,000 kg/day/HRS, ~4,000 kg of LH₂ storage is deployed, whereas for the higher

demand level (5,000 kg/day/HRS), ~10,500 kg of LH₂ storage is considered. Therefore, storage costs are not calculated separately for the LH₂ scenario.

The specific cost of storage $SC_{storage}$ was calculated using the following equation:

$$SC_{storage} = \frac{IC_{storage} \cdot (CRF_{storage} + FC_{storage})}{\text{Annual delivered useable hydrogen}} \quad \text{Eq. 14}$$

where $IC_{storage}$ is the investment cost related to hydrogen storage, $CRF_{storage}$ is the capital recovery factor for storage, and $FC_{storage}$ is the fixed operation and maintenance cost of the storage, given as a percentage of the investment costs.

Photo: Jacob Meissner, Unsplash



5.8 Dispensing

The dispensing costs were obtained by using the HDRSAM modelling tool³¹ provided by Argonne National Laboratory. From HDRSAM, a cost for hydrogen dispensing at 350 bar is obtained as USD per kilogram of hydrogen dispensed (\$/kg H₂). The modelling tool makes several assumptions related to delivery but, as an example, the delivery method, dispensing pressure, and several other factors can be freely changed. A vehicle tank capacity of 50 kg was used for all dispensing cost calculations. A dispensing cost is given separately for LH₂ and CGH₂ even though in all scenarios the hydrogen is dispensed as CGH₂ at 350 bar. The dispensing costs are presented in *Table 5*. A conversion rate from \$ to €, presented in *Section 5.2*, of 1 \$ = 0.92 € is used.

Table 5. Dispensing costs based on the HDRSAM modelling tool

1,000 kg/day	CGH ₂	1.14 €/kg H ₂
	LH ₂	1.46 €/kg H ₂
5,000 kg/day	CGH ₂	0.79 €/kg H ₂
	LH ₂	0.58 €/kg H ₂

5.9 Results

A total delivery cost ($SC_{delivery}$) was obtained for all three scenarios by adding all costs presented in the previous subsections. The results are presented separately for both demand levels.

As can be found from the total delivery cost overview in *Figure 5*, delivery of hydrogen as a liquid is the most expensive alternative (~8 €/kg H₂) with the AFIR-only demand level (1,000 kg/day/HRS). As expected, due to the energy-intensiveness of the process, liquefaction cost accounts for more than a third of the estimated total delivery cost for LH₂. In all three scenarios, a major part of the total delivery cost is the hydrogen production cost. For the on-site scenario,

³¹ <https://hdsam.es.anl.gov/index.php?content=hdsam>

the hydrogen production cost makes up approximately two thirds of the cost. The cost of producing the hydrogen on-site at the HRS is around 7 €/kg H₂. The cheapest delivery alternative is producing the hydrogen semi-centrally and transporting it as a compressed gas which adds up to ~5 €/kg H₂.

When comparing the delivery of hydrogen as a compressed gas (CGH₂) vs. liquid (LH₂), CGH₂ delivery is in this case cheaper up to 2 €/kg H₂. Despite the trucking costs being approximately three times larger with CGH₂ delivery than for LH₂ delivery, the liquefaction process is so expensive that delivery as a liquid does not pay off according to the estimates conducted in this study. Even if the delivery distance is increased significantly, the trucking and processing costs are not large enough to even out the differences. The difference between the cost of delivery in semi-central scenario with both demand levels is 2 €/kg H₂. However, the significance of the trucking costs increases with distance. As an example, with a delivery distance of 400 km, the trucking costs of CGH₂ delivery are already ~1 €/kg H₂.

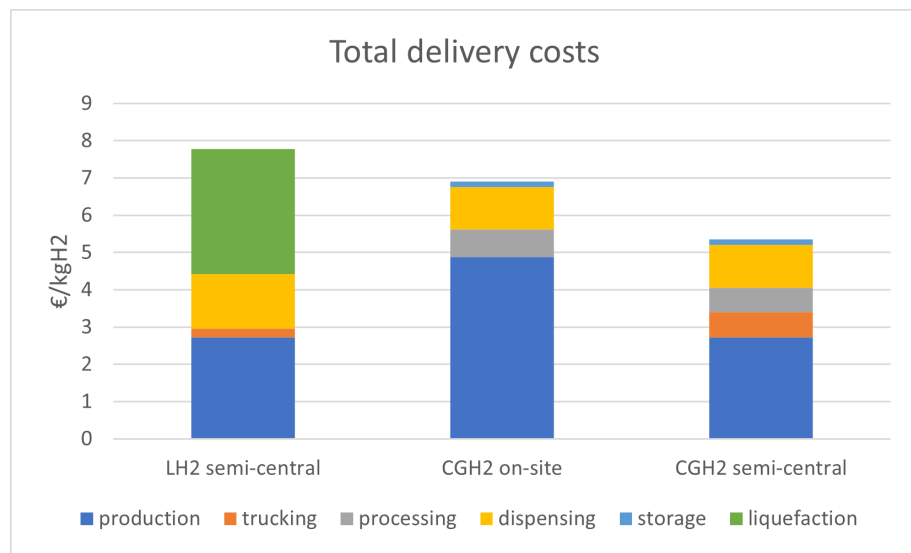

Figure 5. Total delivery costs with a hydrogen demand of 1,000 kg/day and a 200 km delivery distance.

LH₂ delivery is more expensive also with the higher demand level (5,000 kg/day/HRS), as seen from Figure 6. The figure only includes two scenarios since on-site production at the higher demand level was not investigated. Even when the delivery distance is increased significantly to 400 km, the semi-central CGH₂ delivery is still the cheapest option. Although, the difference between the two scenarios is approximately 1.5 €/kg H₂. Liquefaction costs are large (around half of the total cost). Regarding CGH₂, there is much uncertainty related to compression costs which are likely to be much higher than presented here. In addition, concerning the higher pressure level, the compression and processing costs would increase even further. Also, when transporting CGH₂ for longer distances, the trucking costs increase significantly making the gap between the cost of CGH₂ and LH₂ delivery even smaller. It is worth to note that both processing and dispensing costs make up a large portion of the delivery cost. The cost of trucking is also significant but varies with distance.

The total delivery costs of transporting hydrogen in selected scenarios are shown in *Figure 7*. The figure illustrates that LH₂ delivery is not always the most expensive alternative, especially when compared to smaller scale on-site hydrogen production. According to the estimate of this case study, producing hydrogen on-site with a hydrogen demand of 1,000 kg/day is more expensive by ~1 €/kg H₂ than producing hydrogen semi-centrally, liquefying it, and transporting it to the HRS for a distance of 200 km when the hydrogen demand is 5,000 kg/day/HRS. However, delivering hydrogen as a compressed gas at 200 bar seems to be the cheapest alternative regardless of the demand level. Although, as pointed out earlier, there are still uncertainties regarding compression costs. In addition, with very longer delivery distances the trucking costs of CGH₂ will increase more than with LH₂ delivery.

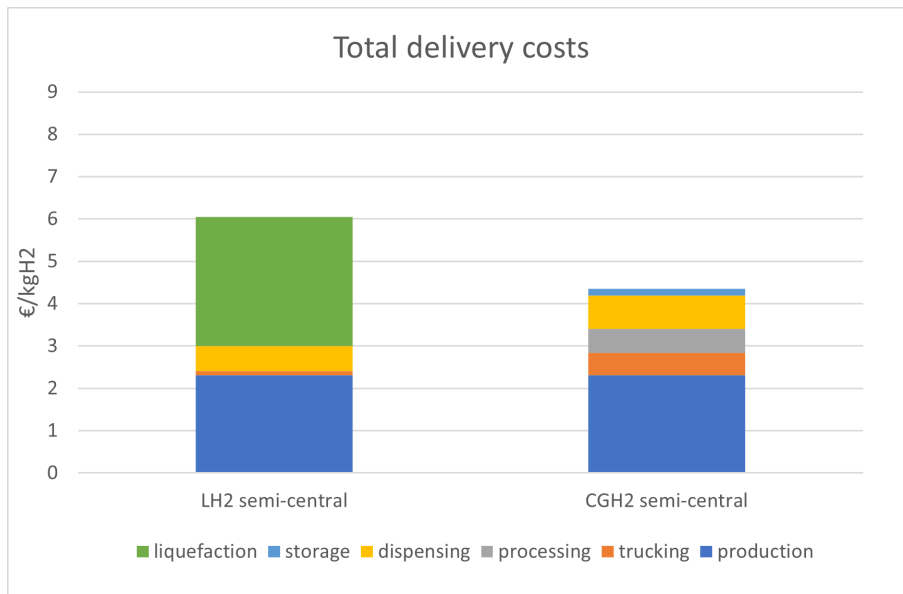

Figure 6. Total delivery costs with a hydrogen demand of 5,000 kg/day and a 200 km delivery distance.

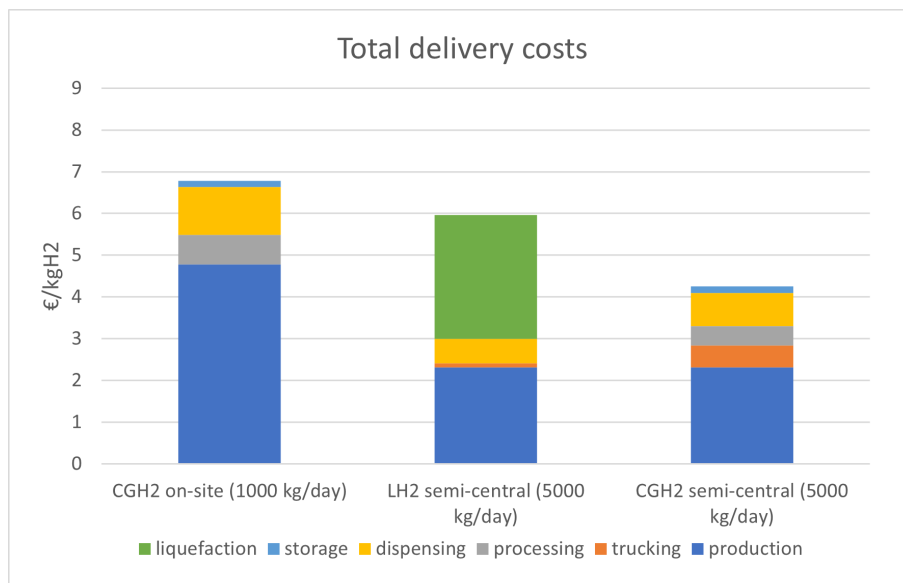

Figure 7. Total delivery costs from selected scenarios with a 200 km delivery distance.

Some sensitivity analyses were performed for the results. Because the hydrogen production costs make a large portion of the total delivery costs, it is important to minimize these costs. Although, the production costs rely heavily on the estimated investment value for electrolysis. The investment cost decreases when the technology-readiness and market deployment is high, and these costs cannot directly be influenced.

As mentioned, the hydrogen production cost is sensitive to electricity price and, therefore, increasing the electricity price results in an increase in the production costs. As an example, by increasing the electricity cost by 20% results in approximately 12% increase in the specific hydrogen production cost with the lower hydrogen demand. For the larger hydrogen demand, a 20% increase in the electricity price results in a 15% increase in the specific cost of hydrogen production. This further highlights the fact that cheap electricity is important when producing hydrogen. Although not only is it important for the electricity to be cheap but also for the investment costs of the electrolyser system to be reasonable since it is the major cost component.

For liquefaction, increasing the electricity cost does not result in such a large increase in the specific cost as for hydrogen production. For instance, increasing the electricity cost of liquefaction by 10% results in a rather modest 1% change in the specific liquefaction cost. The specific cost of liquefaction is, however, more sensitive to the operation and maintenance (O&M) expenses than the electricity cost because of the significant investment cost. The O&M costs are covered by a fixed portion/percentage of the investment cost.

The delivery of CGH₂ was only analysed at a pressure level of 200 bar. This was thought reasonable because although the trucking costs would decrease with hydrogen containers of increased pressure level because of higher hydrogen payload, the dispensing costs increase especially with semi-central cases. Although, more hydrogen can be transported with one truck delivery at a higher pressure level. In addition, the trucking costs generally consist of a relatively small portion of the end costs compared to, for instance, hydrogen production. Therefore, a detailed analysis of trucking with different pressure levels was not performed.

Despite CGH₂ being the cheaper alternative considering the delivery, the difference between LH₂ and CGH₂ delivery is not necessarily large, but differs per scenario. This was highlighted with a sensitivity analysis scenario where the cost of liquefaction was assumed to be cheaper by one fourth and the processing costs that include compression were doubled with the higher hydrogen demand. With these changes, the cost of LH₂ and CGH₂ delivery is approximately the same. This is because of the large liquefaction investment cost. The difference of the two delivery methods is around 1 €/kg H₂ when the cost of processing is doubled.

In this analysis, the focus was on the delivery costs which were compared between CGH₂ and LH₂ but other relevant factors that might affect the deployment of LH₂ technologies in the future were not thoroughly discussed. Relevant factors regarding the deployment of LH₂ technologies include an increased vehicle range which is almost three times larger with vehicles powered by LH₂ than with CGH₂ at 350 bar. The increased range further decreases the investment cost. In addition, LH₂ delivery results in savings during the whole supply chain, including storage, transport, and compression, compared to CGH₂ delivery.



6 References

- Ahluwalia, R. K., Roh, H. S., Peng, J. K., Papadias, D., Baird, A. R., Hecht, E. S., Ehrhart, B. D., Muna, A., Ronevich, J. A., Houchins, C., Killingsworth, N. J., & Aceves, S. M. (2023). *Liquid hydrogen storage system for heavy duty trucks: Configuration, performance, cost, and safety*. *International Journal of Hydrogen Energy*. <https://doi.org/10.1016/j.ijhydene.2022.12.152>
- Air Liquide. (2022). *Air Liquide inaugurates in the U.S. its largest liquid hydrogen production facility in the world*. <https://industry.airliquide.us/air-liquide-inaugurates-us-its-largest-liquid-hydrogen-production-facility-world>
- Aziz, M. (2021). Liquid hydrogen: A review on liquefaction, storage, transportation, and safety. In *Energies* (Vol. 14, Issue 18). MDPI. <https://doi.org/10.3390/en14185917>
- Cardella, U. (2019). *Large-scale Liquid Hydrogen Production and Supply*.
- Cebolla, O., Dolci, R., & Dolci, F. (2022). *Assessment of Hydrogen Delivery Options Feasibility of Transport of Green Hydrogen within Europe*. <https://doi.org/10.2760/869085>
- Connelly, E., Penev, M., Elgowainy, A., & Hunter, C. (2019). *DOE Hydrogen and Fuel Cells Program Record 19001: Current Status of Hydrogen Liquefaction Costs*. https://www.hydrogen.energy.gov/pdfs/19001_hydrogen_liquefaction_costs.pdf
- Daimler. (2022). *Development milestone: Daimler Truck tests fuel-cell truck with liquid hydrogen*. <https://media.daimlertruck.com/marsMediaSite/en/instance/ko/Development-milestone-Daimler-Truck-tests-fuel-cell-truck-with-liquid-hydrogen.xhtml?oid=51975637>
- Decker, L. (2019). *Liquid Hydrogen Distribution Technology*. https://www.sintef.no/globalassets/project/hyper/presentations-day-2/day2_1105_decker_liquid-hydrogen-distribution-technology_linde.pdf
- ECH2A. (2023). *Roadmap on Hydrogen Standardisation*.
- Genovese, M., & Fragiaco, P. (2023). Hydrogen refueling station: Overview of the technological status and research enhancement. *Journal of Energy Storage*, 61, 106758. <https://doi.org/10.1016/j.est.2023.106758>

- Hart, D., Howes, J., Lehner, F., Dodds, P., Hughes, N., Fais, B., Sabio, N., & Crowther, M. (2015). *Scenarios for deployment of hydrogen in contributing to meeting carbon budgets and the 2050 target*. www.e4tech.com
- Hurskainen, M., & Ihonen, J. (2020). Techno-economic feasibility of road transport of hydrogen using liquid organic hydrogen carriers. *International Journal of Hydrogen Energy*, 45(56), 32098–32112. <https://doi.org/10.1016/j.ijhydene.2020.08.186>
- Ihonen, J., Grzelec, A., Wiberg, E., Aronsson, B., Skúlason, J. B., Laustsen Jensen, T., Ingebjørg Telnes Wilhelmsen, & Eriksen, J. (2021). *NEXT NORDIC GREEN TRANSPORT WAVE-LARGE VEHICLES Hydrogen transport from large-scale production points to Nordic consumers Overview-hydrogen transport from large-scale production points to consumers in all Nordic countries*. <http://www.nordichydrogenpartnership.com/nextwave/rapporter/>
- Ihonen, J., Grzelec, A., Wiberg, E., Aronsson, B., Skúlason, J. B., Laustsen Jensen, T., Linnerud, K., & Eriksen, J. (2020). *NEXT NORDIC GREEN TRANSPORT WAVE-LARGE VEHICLES Available by-product hydrogen in the Nordic countries Deliverable 2.1*. <http://www.nordichydrogenpartnership.com/nextwave/rapporter/>
- Ihonen, J., Viik, S., & Hurskainen, M. (2021). *NEXT NORDIC GREEN TRANSPORT WAVE-LARGE VEHICLES Detailed analysis for large-scale hydrogen transport in Finland*.
- International Energy Agency (IEA). (2022). *Global Hydrogen Review 2022*. www.iea.org/t&c/
- Khan, M. A., Young, C., Mackinnon, C. B., & Layzell, D. B. (2021). The Techno-Economics of Hydrogen Compression. *TRANSITION ACCELERATOR TECHNICAL BRIEFS*, 1, 1–36. www.transitionaccelerator.ca
- Li, X. J., Allen, J. D., Stager, J. A., & Ku, A. Y. (2020). Paths to low-cost hydrogen energy at a scale for transportation applications in the USA and China via liquid-hydrogen distribution networks. In *Clean Energy* (Vol. 4, Issue 1, pp. 26–47). Oxford University Press. <https://doi.org/10.1093/ce/zkz033>
- Proost, J. (2019). State-of-the art CAPEX data for water electrolyzers, and their impact on renewable hydrogen price settings. *International Journal of Hydrogen Energy*, 4406–4413. <https://doi.org/10.1016/j.ijhydene.2018.07.164>
- U.S. Department of Energy. (2015). *Hydrogen and Fuel Cell Technologies Office Multi-Year Research, Development, and Demonstration Plan*. Hydrogen and Fuel Cell Technologies Office Multi-Year Research, Development, and Demonstration Plan
- Ustolin, F., Campari, A., & Tacani, R. (2022). An Extensive Review of Liquid Hydrogen in Transportation with Focus on the Maritime Sector. In *Journal of Marine Science and Engineering* (Vol. 10, Issue 9). MDPI. <https://doi.org/10.3390/jmse10091222>

7 Appendix

7.1 Methodology for calculating the number of trucks and trailers required

In this section, the relevant equations and assumption related to trucks and trailers are presented. The section is an adapted version of the Appendix section in Next Wave Deliverable 2.5 with the same name.

When determining the required number of trucks and trailers, firstly the required number of deliveries is determined:

$$\text{required deliveries per day (day}^{-1}\text{)} = \frac{\text{Hydrogen demand (kg day}^{-1}\text{)}}{\text{Net hydrogen payload (kg)}}$$

When the required number of deliveries is determined, the total trip time in hours can be calculated:

$$\begin{aligned} \text{total trip time (h)} \\ &= \frac{2 \cdot \text{one - way distance (km)}}{\text{average driving speed (km h}^{-1}\text{)}} + \text{loading time (h)} \\ &+ \text{unloading time (h)} \end{aligned}$$

A theoretical maximum number of trips for each truck per day can then be calculated:

$$\text{max \# of trips per day per truck (day}^{-1}\text{truck}^{-1}\text{)} = \frac{24\text{h}}{\text{total trip time (h)}}$$

Required number of trucks was calculated using the required number of deliveries to meet the demand and the theoretical maximum number of trips each truck can make in one day by also considering the availability of trucks:

$$\text{required \# of trucks} = \frac{\text{required deliveries per day}}{\text{max \# of trips per day per truck} \cdot \text{truck availability (\%)}}$$

This number was rounded up to nearest larger integer. After rounding up, the lowest number of trips per day per truck that meets the hydrogen demand allowing also non-integer numbers is used in the analysis. For instance, 0.5 trips per day per truck could mean delivery every second day.

The number of trailers needed for gaseous / compressed hydrogen (CGH₂) delivery options is three times the number of trucks: one is being transported, one is being filled up at the hydrogen source and one is being emptied at the hydrogen consumer. The trailers act as storages and thus no additional

storages are needed. In case of liquid hydrogen transport, the trucks will wait while the tanker trailer is first unloaded and then loaded. Thus, storage tanks are required for LH₂ delivery.

7.2 Methodology for calculating trucking costs

In this section, the relevant equations and assumption related to trucking costs are presented. The section is an adapted version of the Appendix section in Next Wave Deliverable 2.5 with the same name.

The annualized investment costs for truck fleets ($IC_{ann, trucking}$) where calculated by considering the required number of trucks and trailers and their investment costs (IC) and capital recovery factors (CRF):

$$IC_{ann, trucking} = (\# \text{ of trucks}) \cdot CRF_{truck} \cdot IC_{truck} + (\# \text{ of trailers}) \cdot CRF_{trailer} \cdot IC_{trailer}$$

Operation and maintenance costs (in €/kg H₂) were calculated from the specified variable (VC) and fixed costs (FC) of the trucks and trailers:

$$SC_{trucking, O\&M} = \frac{(\# \text{ of trucks}) \cdot VC_{truck} \cdot (\text{annual drive distance}) + (\# \text{ of trailers}) \cdot (IC_{trailer} \cdot FC_{trailer})}{\text{Delivered useable hydrogen per year}}$$

Personnel cost for each kg of hydrogen delivered depends on the total trip time, hourly salary of the driver, and delivered amount of useable hydrogen per truck:

$$SC_{trucking, personnel} = \frac{(\text{total trip time}) \cdot (\text{hourly salary})}{\text{Delivered useable hydrogen per truck}}$$

The specific delivery costs due to fuel consumption of truck can be calculated from drive distance, fuel consumption, fuel price, and delivered amount of useable hydrogen:

$$SC_{trucking, fuel} = \frac{2 \cdot (\text{one - way distance}) \cdot \text{fuel consumption} \cdot \text{fuel price}}{\text{Delivered useable hydrogen per truck}}$$

The total specific hydrogen delivery cost from trucking then becomes:

$$SC_{trucking} = \frac{IC_{trucking} \cdot CRF_{trucking}}{\text{Delivered useable hydrogen per year}} + SC_{trucking, O\&M} + SC_{trucking, fuel} + SC_{trucking, personnel}$$

Next Nordic Green Transport Wave - Large Vehicles

Deliverable 2.6

**Analysis on large-scale transport of
liquid hydrogen on Nordic roads**

Version 1.0

2023

